



 **Primary 6 Science (Term 2) - Nanyang (Y0)** 

Add Questions **Assign** **Settings** **Review**

 Duplicate  Print  Delete

 **Assign Test**

Test Introduction

[+ Add Introduction](#)

61 Questions (61 Points)

Question Bank: 12,655 Questions 

Test Questions **0 Test Assignments**

Question 1

Primary 6 Science » Primary 6 Science (Term 2)

2 pts

For each question, four options are given. One of them is the correct answer. Indicate your choice of the answer below. (56 marks)

Study the diagram below.

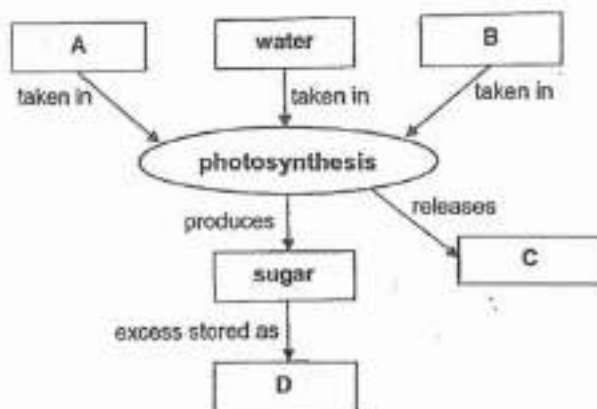

Which one of the following correctly represents substances A, B, C and D in the diagram?

- A.

A	B	C	D
light energy	oxygen	carbon dioxide	starch
- B.

A	B	C	D
heat energy	carbon dioxide	oxygen	sugar
- C.

A	B	C	D
heat energy	oxygen	carbon dioxide	sugar

✓ D.

A	B	C	D
light energy	carbon dioxide	oxygen	starch

Question Type: Multiple Choice
Randomize Answers: No
Date Added: Sat 2nd Oct 2021
Last Modified: N/A
QID#: 29,206,034

[Answers](#) | [Edit](#) | [Duplicate](#) | [Used In](#) | [Reorder](#)

[Remove From Test](#)

Question 2

Primary 6 Science » Primary 6 Science (Term 2)

2 pts

The diagram below shows how food and water are transported to different parts of a flowering plant.

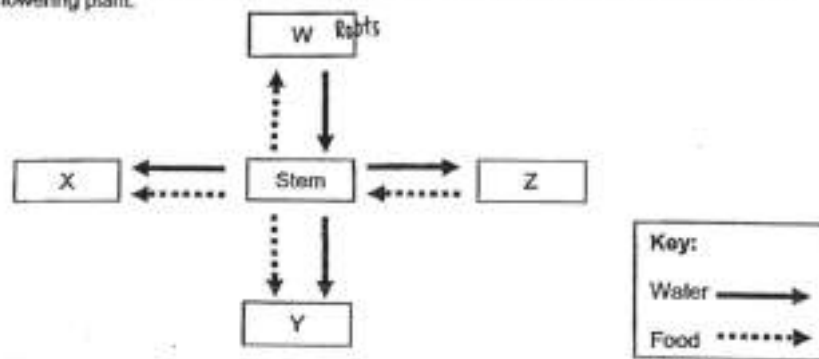

Which of the following correctly identifies the parts of the plant?

A.

W	X	Y	Z
Flower	Roots	Leaves	Fruit

B.

W	X	Y	Z
Leaves	Flower	Fruit	Roots

✓ C.

W	X	Y	Z
Roots	Fruit	Flower	Leaves

D.

W	X	Y	Z
Roots	Flower	Leaves	Fruit

Question Type: Multiple Choice
Randomize Answers: No
Date Added: Sat 2nd Oct 2021
Last Modified: N/A
QID#: 29,206,041

[Answers](#) | [Edit](#) | [Duplicate](#) | [Used In](#) | [Reorder](#)

[Remove From Test](#)

Question 3

Primary 6 Science » Primary 6 Science (Term 2)

2 pts

The diagram below shows the human digestive system.

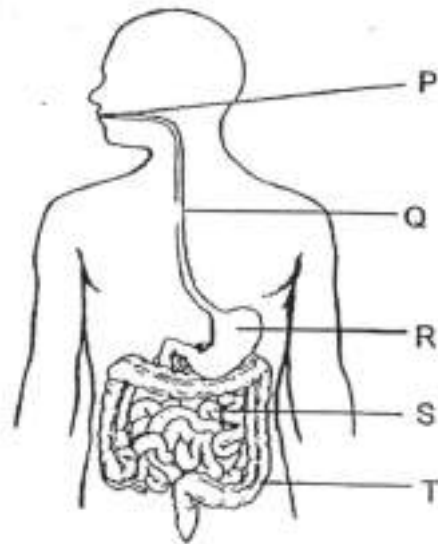

Which of the following statements about the digestive system are correct?

- A Digestion begins at part Q.
- B Parts P and R contain digestive juices.
- C Water is absorbed from the undigested food at part T.
- D Undigested food is absorbed into the bloodstream at part S.

- A. A and D only
- ✓ B. B and C only
- C. B, C and D only
- D. A, B, C and D

Question Type: Multiple Choice
Randomize Answers: No
Date Added: Sat 2nd Oct 2021
Last Modified: N/A
QID#: 29,206,045

[Answers](#) | [Edit](#) | [Duplicate](#) | [Used In](#) | [Reorder](#)

[Remove From Test](#)

Question 4

Primary 6 Science » Primary 6 Science (Term 2)

2 pts

Vinette placed a pot of plant in a dark room for 3 days. She then set up the following experiment under the sun for a few days to find out the effect of carbon dioxide on photosynthesis. Liquids S and T were placed in each of the plastic bags as shown below.

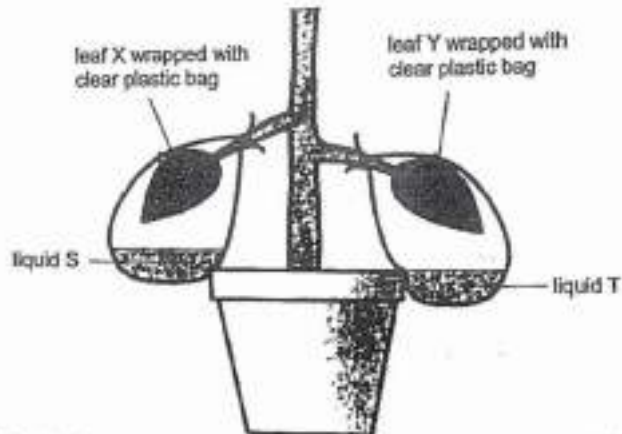

Vinette then conducted a starch test on both leaves and recorded her results in the table below.

	Leaf X	Leaf Y
Colour of iodine solution after starch test	Yellowish-brown	Dark blue

Based only on the results above, which of the following statements is true?

- A. Liquid S had produced oxygen in the plastic bag.
- B. Liquid T had produced oxygen in the plastic bag.
- ✓ C. Liquid S had removed carbon dioxide from the plastic bag.
- D. Liquid T had removed carbon dioxide from the plastic bag.

Question Type: Multiple Choice
 Randomize Answers: No
 Date Added: Sat 2nd Oct 2021
 Last Modified: N/A
 QID#: 29,206,051

[Answers](#) |
 [Edit](#) |
 [Duplicate](#) |
 [Used In](#) |
 [Reorder](#)

[Remove From Test](#)

Question 5

Primary 6 Science » Primary 6 Science (Term 2)

2 pts

Harry wanted to find out how the intensity of light affects the rate of photosynthesis of plant A. He set up an experiment in a dark room as shown below.

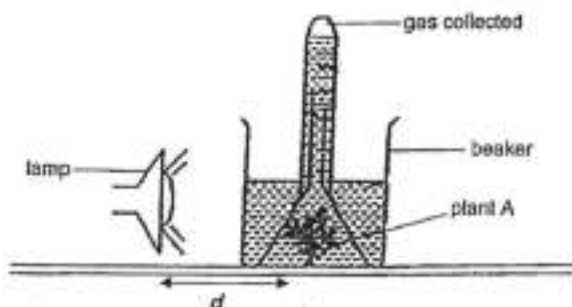

He prepared four similar set-ups with different distances, d , from plant A. He measured and recorded the amount of oxygen collected in the test tube for each set-up. Based on the experiment above, which one of the following graphs shows the most likely result?

A.

Amount of oxygen
(units)

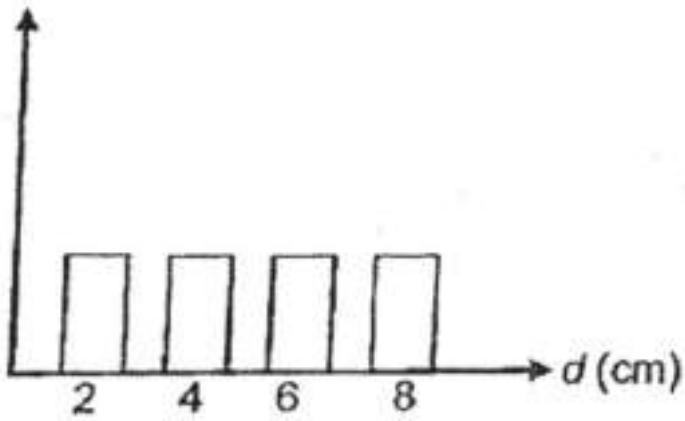

B.

Amount of oxygen
(units)

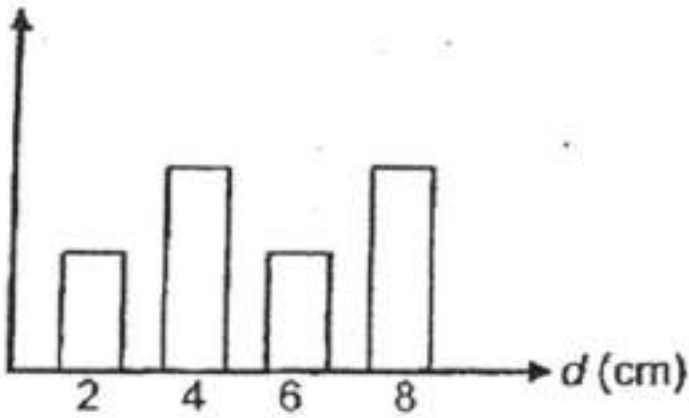

C.

Amount of oxygen
(units)

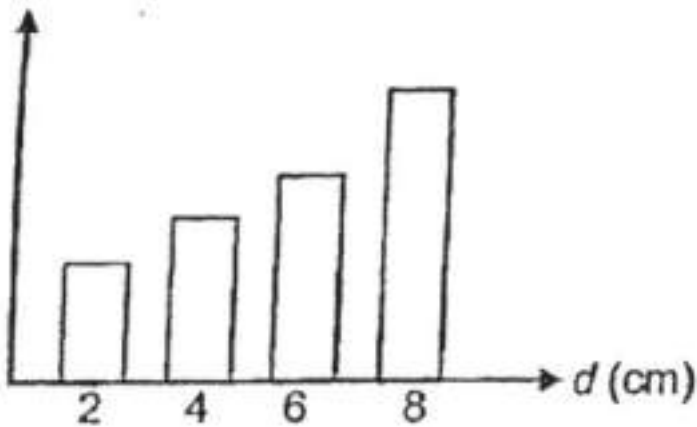

✓ D.

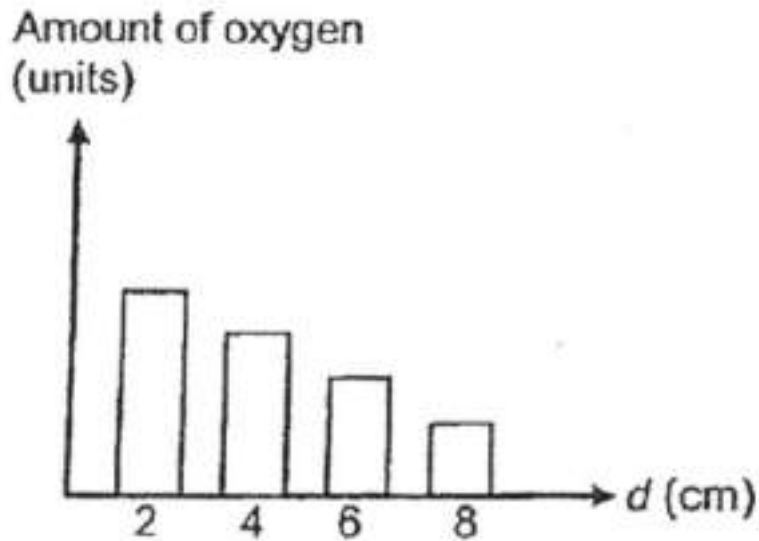

Question Type: Multiple Choice
Randomize Answers: No
Date Added: Sat 2nd Oct 2021
Last Modified: N/A
QID#: 29,206,054

[Answers](#) | [Edit](#) | [Duplicate](#) | [Used In](#) | [Reorder](#)

[Remove From Test](#)

Question 6

Primary 6 Science » Primary 6 Science (Term 2)

2 pts

Which of the following get(s) its/their energy directly from the sun?

- A Fern
- B Grass
- C Mould
- D Mushroom

- A. B only
- ✓ B. A and B only
- C. A and D only
- D. C and D only

Question Type: Multiple Choice
Randomize Answers: No
Date Added: Sat 2nd Oct 2021
Last Modified: N/A
QID#: 29,206,059

[Answers](#) | [Edit](#) | [Duplicate](#) | [Used In](#) | [Reorder](#)

[Remove From Test](#)

Question 7

Primary 6 Science » Primary 6 Science (Term 2)

2 pts

Molly placed 4 identical plants, A, B, C and D, under different conditions. She then tested the leaves of the plants for starch after 4 days and recorded the results as shown in the table below.

Plant	Fertiliser added	Presence of light	Presence of starch
A	yes	yes	present
B	yes	no	absent
C	no	yes	present
D	no	no	absent

Based only on the results shown above, what can Molly conclude?

- ✓ A. Light is needed for photosynthesis to take place.
- B. Fertiliser is needed for photosynthesis to take place.
- C. Light and fertiliser are needed for photosynthesis to take place.
- D. Light and fertiliser are not needed for photosynthesis to take place.

Question Type: Multiple Choice
 Randomize Answers: No
 Date Added: Sat 2nd Oct 2021
 Last Modified: N/A
 QID#: 29,206,068

[Answers](#) |
 [Edit](#) |
 [Duplicate](#) |
 [Used In](#) |
 [Reorder](#)

[Remove From Test](#)

Question 8

Primary 6 Science » Primary 6 Science (Term 2)

2 pts

The diagram below represents the water cycle.

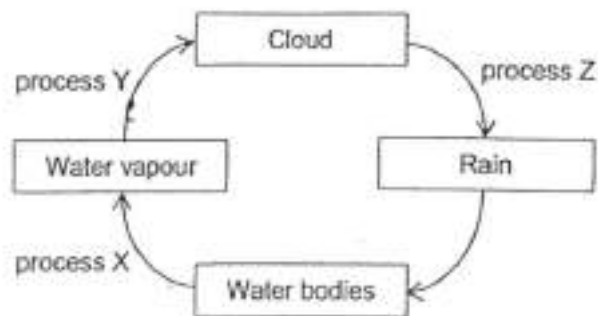

Which of the following statements about the water cycle are correct?

- A. Process X can only take place at 100°C.
 - B. Process X occurs when water gains heat.
 - C. There is no change in state during process Z.
 - D. Process Y can only take place when there is no temperature difference.
- A. A and B only
 - ✓ B. B and C only
 - C. C and D only
 - D. A, B, C and D

Question Type: Multiple Choice

Randomize Answers: No
 Date Added: Sat 2nd Oct 2021
 Last Modified: N/A
 QID#: 29,206,071

Answers | Edit | Duplicate | Used In | Reorder

Remove From Test

Question 9

Primary 6 Science » Primary 6 Science (Term 2)

2 pts

Tim set up an experiment as shown below. He set up four beakers in a classroom of temperature 28°C for 30 minutes and observed water droplets on some of the beakers.

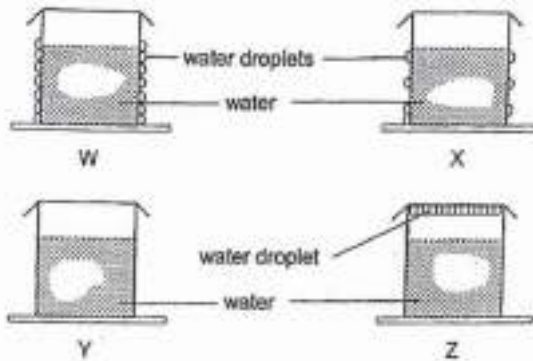

Which one of the following shows the correct order of temperatures of the four beakers of water, from the lowest to the highest?

- A.

Lowest Temperature		Highest Temperature
Y	X W	Z
- B.

Lowest Temperature		Highest Temperature
Z	Y X	W
- C.

Lowest Temperature		Highest Temperature
W	Y X	Z
- ✓ D.

Lowest Temperature		Highest Temperature
W	X Y	Z

Question Type: Multiple Choice
 Randomize Answers: No
 Date Added: Sat 2nd Oct 2021
 Last Modified: N/A
 QID#: 29,206,083

Answers | Edit | Duplicate | Used In | Reorder

Remove From Test

Question 10

Primary 6 Science » Primary 6 Science (Term 2)

2 pts

Which of the following ways help to conserve water?

- A Collecting rainwater to water the plants.
- B Turning off the taps when they are not in use.

- C Installing solar panels on the roof of the house.
- D Switching off the air-conditioner when not in use.

- ✓ A. A and B only
- B. C and D only
- C. A, B and D only
- D. A, C and D only

Question Type: Multiple Choice
Randomize Answers: No
Date Added: Sat 2nd Oct 2021
Last Modified: N/A
QID#: 29,206,090

[Answers](#) | [Edit](#) | [Duplicate](#) | [Used In](#) | [Reorder](#)

[Remove From Test](#)

Question 11

Primary 6 Science » Primary 6 Science (Term 2)

2 pts

Which of the following statements about evaporation and boiling of liquids are correct?

- A Both can take place in the dark.
 - B Both occur at a fixed temperature.
 - C Both involve the same change in states of matter.
 - D Both require heat gain of the liquids from the surroundings.
-
- A. A and B only
 - B. B and C only
 - C. C and D only
 - ✓ D. A, C and D only

Question Type: Multiple Choice
Randomize Answers: No
Date Added: Sat 2nd Oct 2021
Last Modified: N/A
QID#: 29,206,099

[Answers](#) | [Edit](#) | [Duplicate](#) | [Used In](#) | [Reorder](#)

[Remove From Test](#)

Question 12

Primary 6 Science » Primary 6 Science (Term 2)

2 pts

Cathy placed a thermometer in a beaker of boiling water. After some time, she placed the beaker of water in the freezer at 0°C and recorded the change in temperature of the water in the graph below.

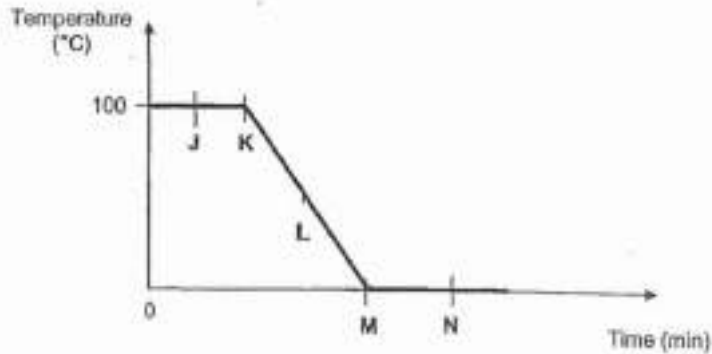

Based on the graph above, which of the following statements are true?

- A Water lost heat from point K to point L.
- B Ice can be observed in the beaker at point N.
- C The beaker was placed in the freezer at point J.
- D No evaporation occurred from point L to point M.

- A. B only
- ✓ B. A and B only
- C. C and D only
- D. A, B, C and D

Question Type: Multiple Choice
 Randomize Answers: No
 Date Added: Sat 2nd Oct 2021
 Last Modified: N/A
 QID#: 29,206,102

[Answers](#) |
 [Edit](#) |
 [Duplicate](#) |
 [Used In](#) |
 [Reorder](#)

[Remove From Test](#)

Question 13

Primary 6 Science » Primary 6 Science (Term 2)

2 pts

Ahmad set up an experiment as shown in the diagram below.

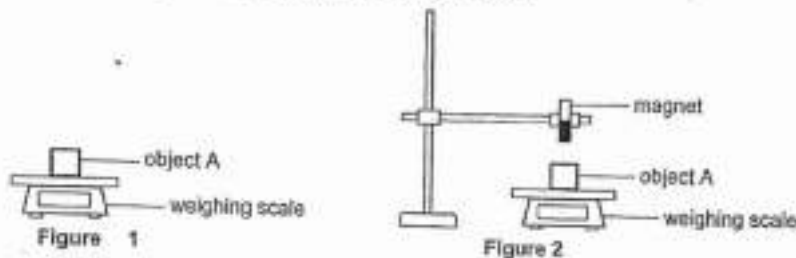

He placed object A on the weighing scale and recorded the reading. A bar magnet was then brought near object A and the new reading was recorded. He repeated the steps with objects B and C. Objects A, B and C are made of different materials.

His results are shown in the table below.

Reading on weighing scale (g)	Figure 1	Figure 2
Object A	12.0	13.5
Object B	15.0	15.0
Object C	18.5	14.0

Based on Ahmad's results above, which of the following are likely to be objects A, B and C?

- A.

Object A	Object B	Object C
steel block	magnet	wooden block
- B.

Object A	Object B	Object C
wooden block	steel block	magnet
- C.

Object A	Object B	Object C
steel block	wooden block	magnet
- ✓ D.

Object A	Object B	Object C
magnet	wooden block	steel block

Question Type: Multiple Choice
Randomize Answers: No
Date Added: Sat 2nd Oct 2021
Last Modified: N/A
QID#: 29,206,114

[Answers](#) | [Edit](#) | [Duplicate](#) | [Used In](#) | [Reorder](#)

[Remove From Test](#)

Question 14

Primary 6 Science » Primary 6 Science (Term 2)

2 pts

The set-up below shows light from a torch shining on three solid objects of the same height but made of different materials. All three objects are placed in a straight line at positions X, Y and Z.

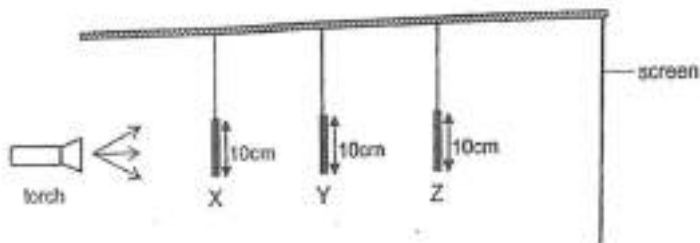

The diagram below shows the shadow formed on the screen.



Which of the following would allow the shadow above to be formed?

- A.

X	Y	Z
wood	wood	metal
- ✓ B.

X	Y	Z
tracing paper	metal	clear glass
- C.

X	Y	Z
clear glass	wood	metal

D.

X	Y	Z
metal	tracing paper	wood

Question Type: Multiple Choice
Randomize Answers: No
Date Added: Sat 2nd Oct 2021
Last Modified: N/A
QID#: 29,206,127

[Answers](#) | [Edit](#) | [Duplicate](#) | [Used In](#) | [Reorder](#)

[Remove From Test](#)

Question 15

Primary 6 Science » Primary 6 Science (Term 2)

2 pts

The table below shows the state of substances W, X, Y and Z at different temperatures.

Substance	State of substance		
	2°C	65°C	95°C
W	liquid	liquid	gas
X	liquid	gas	gas
Y	solid	solid	solid
Z	liquid	liquid	liquid

Which of the following statements about the substances are correct?

- A Substance W is a liquid at 40°C.
- B Substance Y has the lowest melting point.
- C Substance Z has the highest freezing point.
- D Substance X has a lower boiling point than substance W.

- A. A and C only
- ✓ B. A and D only
- C. B and C only
- D. A, B, C and D

Question Type: Multiple Choice
Randomize Answers: No
Date Added: Sat 2nd Oct 2021
Last Modified: N/A
QID#: 29,206,133

[Answers](#) | [Edit](#) | [Duplicate](#) | [Used In](#) | [Reorder](#)

[Remove From Test](#)

Question 16

Primary 6 Science » Primary 6 Science (Term 2)

2 pts

Jun Wei covered a ramp with material P and released a wooden block from the top the ramp. He then measured, d , the distance that the wooden block slid across the floor before coming to a stop, as shown in the diagram below.

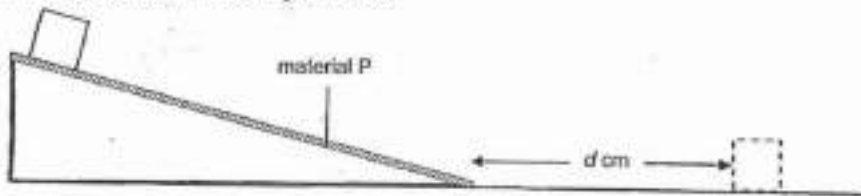

He repeated the experiment with three other materials, Q, R and S. The results of his experiment is shown in the table below.

Material	P	Q	R	S
d (cm)	2.9	8.1	6.4	7.2

Based on the results of Jun Wei's experiment, which material, P, Q, R or S, is the most suitable to be used for making part Y of the anti-slip socks as shown in the diagram below?



- ✓ A. P
- B. Q
- C. R
- D. S

Question Type: Multiple Choice
Randomize Answers: No
Date Added: Sat 2nd Oct 2021
Last Modified: N/A
QID#: 29,206,135

[Answers](#) | [Edit](#) | [Duplicate](#) | [Used In](#) | [Reorder](#)

[Remove From Test](#)

Question 17

Primary 6 Science » Primary 6 Science (Term 2)

2 pts

Ravi hung a weighing pan from a spring as shown in the diagram below.

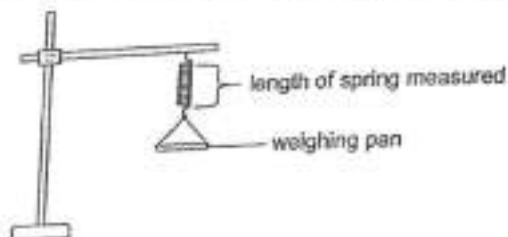

He placed identical marbles on the weighing pan, one at a time, and measured the length of the spring.

Which one of the following graphs most likely shows the results of Ravi's experiment?

- A.

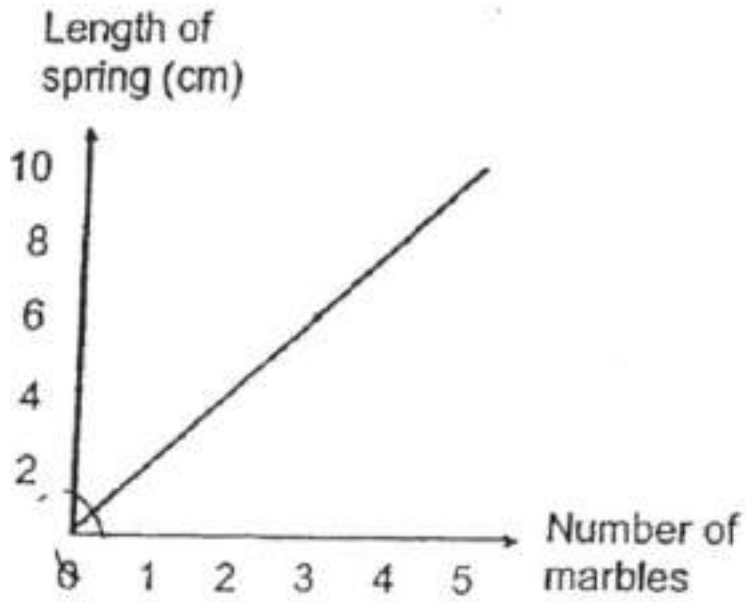

B.

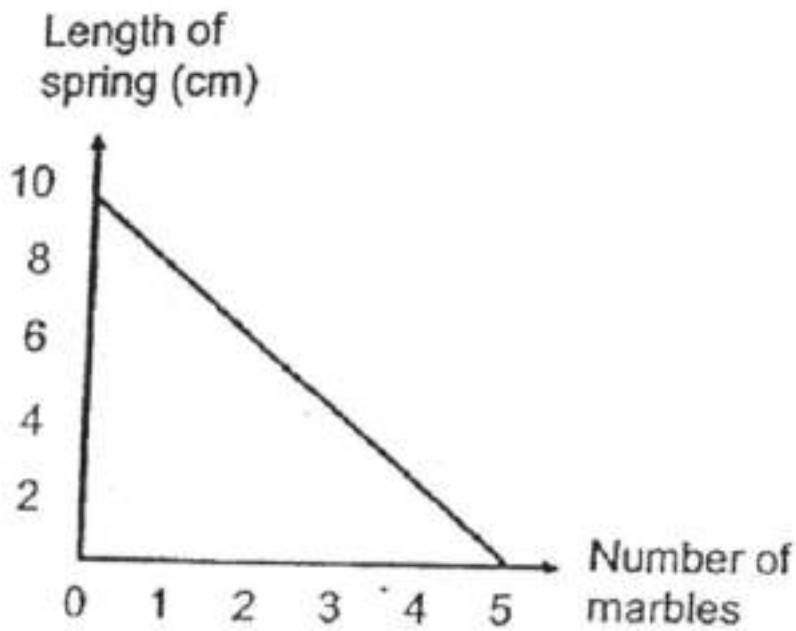

✓ c.

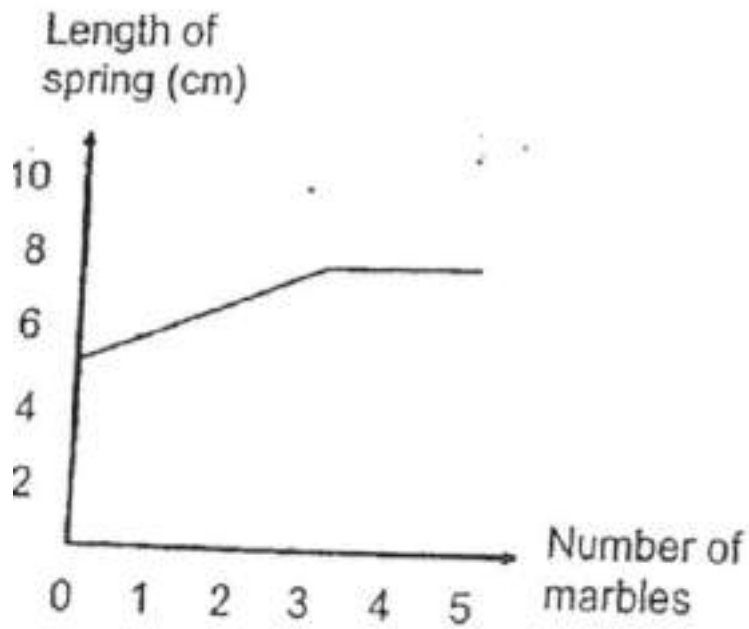

D.

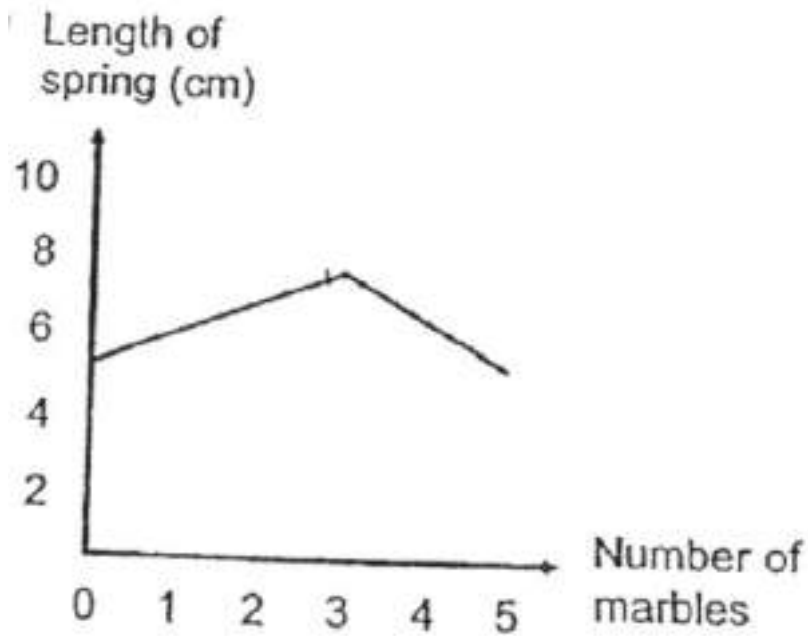

Question Type: Multiple Choice
 Randomize Answers: No
 Date Added: Sat 2nd Oct 2021
 Last Modified: N/A
 QID#: 29,206,141

[Answers](#) | [Edit](#) | [Duplicate](#) | [Used In](#) | [Reorder](#)

[Remove From Test](#)

Question 18

Primary 6 Science » Primary 6 Science (Term 2)

2 pts

Zi Le released a toy parachute from the air as shown in the diagram below.

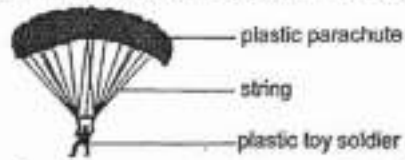

Which of the following forces are present as the toy parachute falls slowly through the air?

- A Magnetic force
- B Frictional force
- C Gravitational force
- D Elastic spring force

- ✓ A. B and C only
- B. B and D only
- C. A, B and C only
- D. A, C and D only

Question Type: Multiple Choice
Randomize Answers: No
Date Added: Sat 2nd Oct 2021
Last Modified: N/A
QID#: 29,206,146

[Answers](#) | [Edit](#) | [Duplicate](#) | [Used In](#) | [Reorder](#)

[Remove From Test](#)

Question 19

Primary 6 Science » Primary 6 Science (Term 2)

2 pts

Study the four circuit diagrams below. All the batteries and bulbs used are identical.

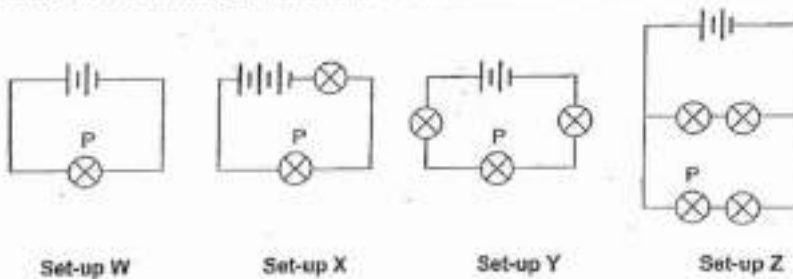

Arrange the set-ups based on the brightness of bulb P, from the brightest to the least bright.

- ✓ A. W, X, Z, Y
- B. X, W, Y, Z
- C. X, Z, Y, W
- D. Z, Y, X, W

Question Type: Multiple Choice
Randomize Answers: No
Date Added: Sat 2nd Oct 2021
Last Modified: N/A
QID#: 29,206,152

[Answers](#) | [Edit](#) | [Duplicate](#) | [Used In](#) | [Reorder](#)

[Remove From Test](#)

Question 20

Primary 6 Science » Primary 6 Science (Term 2)

2 pts

The diagram below shows a circuit diagram with two gaps, P and Q.

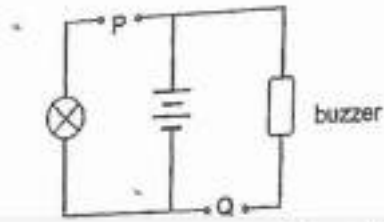

Which one of the following observations is correct when different materials are used to connect gaps P and Q in the circuit?

- A.
- | P | Q | Observations |
|-----------|-------|---|
| aluminium | glass | The bulb lit up and the buzzer sounded. |
- ✓ B.
- | P | Q | Observations |
|------|------|---|
| iron | wood | The bulb lit up but the buzzer did not sound. |
- C.
- | P | Q | Observations |
|--------|---------|---|
| rubber | plastic | The bulb did not light up but the buzzer sounded. |
- D.
- | P | Q | Observations |
|-------|--------|---|
| steel | copper | The bulb did not light up and the buzzer did not sound. |

Question Type: Multiple Choice
Randomize Answers: No
Date Added: Sat 2nd Oct 2021
Last Modified: N/A
QID#: 29,206,171

[Answers](#) | [Edit](#) | [Duplicate](#) | [Used In](#) | [Reorder](#)

[Remove From Test](#)

Question 21

Primary 6 Science » Primary 6 Science (Term 2)

2 pts

Study the circuit diagram below. B1, B2 and B3 are bulbs. S1, S2 and S3 are switches.

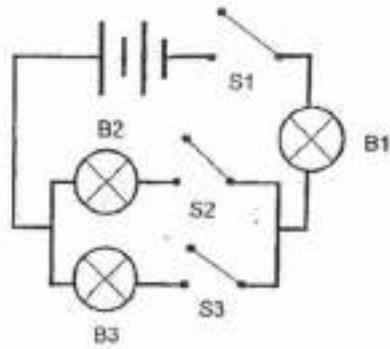

Which of the following statements about the circuit above is/are correct?

- P B1 will light up if either B2 or B3 are lighted.
- Q When only S2 and S3 are closed, B2 and B3 will light up.
- R When all the switches are closed and B3 fuses, only B1 will light up.
- S If B1 fuses, none of the other bulbs will light up even when all the switches are closed.

- A. P only
- ✓ B. P and S only
- C. Q and R only
- D. Q, R and S only

Question Type: Multiple Choice
Randomize Answers: No
Date Added: Sat 2nd Oct 2021
Last Modified: N/A
QID#: 29,206,180

[Answers](#) | [Edit](#) | [Duplicate](#) | [Used In](#) | [Reorder](#)

[Remove From Test](#)

Question 22

Primary 6 Science » Primary 6 Science (Term 2)

2 pts

Which of the following show(s) unsafe use of electricity?

- A Putting in many plugs into one socket
 - B Using electrical appliances with exposed wires
 - C Handling electrical appliances using wet hands
 - D Getting an electrician to repair damaged electrical appliances
- A. D only
 - B. A and C only
 - ✓ C. A, B and C only
 - D. B, C and D only

Question Type: Multiple Choice
Randomize Answers: No
Date Added: Sat 2nd Oct 2021
Last Modified: N/A
QID#: 29,206,189

[Answers](#) | [Edit](#) | [Duplicate](#) | [Used In](#) | [Reorder](#)

[Remove From Test](#)

Question 23

Primary 6 Science » Primary 6 Science (Term 2)

2 pts

Which of the following statements about energy is/are true?

- A Energy is needed by animals only.
- B Energy can exist in different forms.
- C Energy is not needed during sleeping.

- A. B only
- ✓ B. A and C only
- C. B and C only
- D. A, B and C

Question Type: Multiple Choice
Randomize Answers: No
Date Added: Sat 2nd Oct 2021
Last Modified: N/A
QID#: 29,206,198

[Answers](#) | [Edit](#) | [Duplicate](#) | [Used In](#) | [Reorder](#)

[Remove From Test](#)

Question 24

Primary 6 Science » Primary 6 Science (Term 2)

2 pts

Study the circuit diagram below.

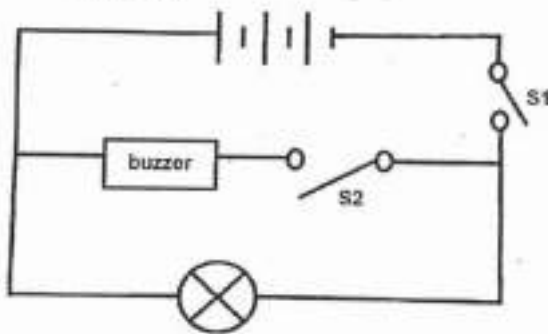

Which of the following shows the correct energy conversions when S2 is opened and S1 is closed?

- A. Electrical energy -----> Sound energy
- B. Potential energy -----> Electrical energy -----> Sound energy
- C. Electrical energy -----> Light energy + Sound energy
- ✓ D. Potential energy -----> Electrical energy -----> Light energy

Question Type: Multiple Choice
Randomize Answers: No
Date Added: Sat 2nd Oct 2021
Last Modified: N/A
QID#: 29,206,207

[Answers](#) | [Edit](#) | [Duplicate](#) | [Used In](#) | [Reorder](#)

[Remove From Test](#)

Question 25

Primary 6 Science » Primary 6 Science (Term 2)

2 pts

Sam made a toy as show below. He stretched the elastic band backward and released it for the ball to be thrown forward.

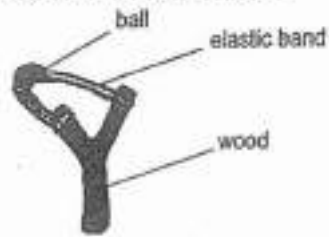

Which of the following changes, when made together, will allow the ball to travel the furthest distance?

- A Using a lighter ball
- B Stretching the elastic band further
- C Using less force to pull the elastic band

- ✓ A. A and B only
- B. A and C only
- C. B and C only
- D. A, B and C

Question Type: Multiple Choice
Randomize Answers: No
Date Added: Sat 2nd Oct 2021
Last Modified: N/A
QID#: 29,206,213

[Answers](#) | [Edit](#) | [Duplicate](#) | [Used In](#) | [Reorder](#)

[Remove From Test](#)

Question 26

Primary 6 Science » Primary 6 Science (Term 2)

2 pts

Mrs Lim conducted an experiment as shown below. She dropped a ball at point A. The class observed that each time the ball hit the ground, it bounced up to a lower height until it finally stopped at point F.

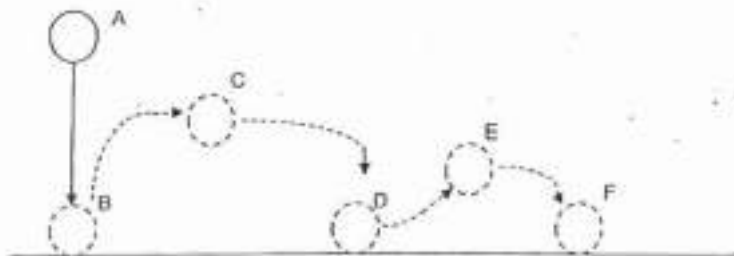

The class made the following conclusions based on the experiment. Which of the following is correct?

- A. The ball has no kinetic energy at D.
- ✓ B. The ball has the most potential energy at A.
- C. The ball has less kinetic energy at B than at F.
- D. The ball has the same amount of potential energy at C and E.

Question Type: Multiple Choice
Randomize Answers: No
Date Added: Sat 2nd Oct 2021
Last Modified: N/A
QID#: 29,206,221

[Answers](#) | [Edit](#) | [Duplicate](#) | [Used In](#) | [Reorder](#)

[Remove From Test](#)

Question 27

Primary 6 Science » Primary 6 Science (Term 2)

2 pts

A ball is tied to a machine as shown in the diagram below. When Tom swings the ball, it hits the toy building which then falls loudly



Which one of the following shows the correct energy conversions involved?

- A. Before releasing ball Ball swinging Building falling**
 Kinetic energy (ball) -----> Kinetic energy (ball) -----> Sound energy (toy building)
- ✓ **B. Potential energy (ball) -----> Kinetic energy (ball) -----> Sound energy (toy building)**
- C. Potential energy (ball) -----> Kinetic energy (ball) -----> Light energy (toy building)**
- D. Kinetic energy (ball) -----> Potential energy (ball) -----> Light energy (toy building)**

Question Type: Multiple Choice
Randomize Answers: No
Date Added: Sat 2nd Oct 2021
Last Modified: N/A
QID#: 29,206,241

[Answers](#) | [Edit](#) | [Duplicate](#) | [Used In](#) | [Reorder](#)

[Remove From Test](#)

Question 28

Primary 6 Science » Primary 6 Science (Term 2)

2 pts

The diagram below shows Adam with his bat and baseball.



Based on the diagram above, which of the following best represents the type of energy possessed by the bat and the baseball **before** Adam swings his bat.

- A.

Bat	Baseball
kinetic energy	kinetic energy
- B.

Bat	Baseball
kinetic energy	potential energy
- C.

Bat	Baseball
potential energy	kinetic energy
- ✓ D.

Bat	Baseball
potential energy	potential energy

Question Type: Multiple Choice
Randomize Answers: No
Date Added: Sat 2nd Oct 2021
Last Modified: N/A
QID#: 29,206,249

[Answers](#) | [Edit](#) | [Duplicate](#) | [Used In](#) | [Reorder](#)

[Remove From Test](#)

Question 29

Primary 6 Science » Primary 6 Science (Term 2)

0 pts

Sean carried out an experiment to find out how the amount of light shining on a plant affects the amount of water it takes in.

The diagram below shows the set-ups of his experiment.

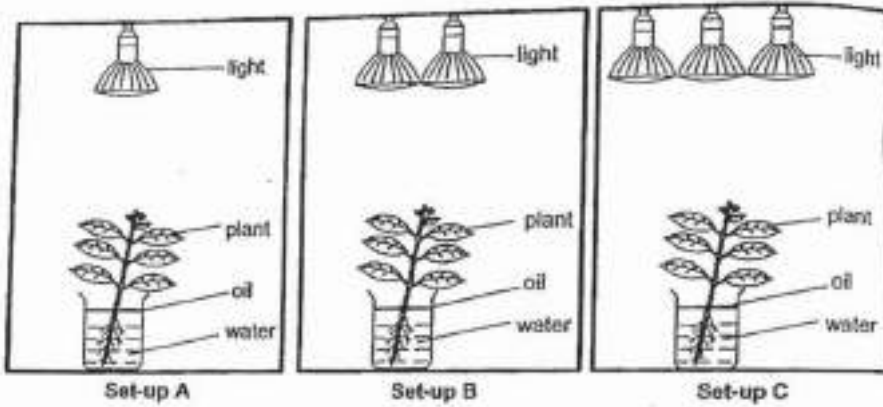

He left the set-ups in the same room and recorded the amount of water left in each beaker after four days.

	Set-up A	Set-up B	Set-up C
Amount of water at the start of the experiment (mℓ)	200	200	200
Amount of water at the end of the experiment (mℓ)	190	184	171

What was the purpose of adding oil to the beaker of water in each set-up? (1 mark)

This question is designed for extended answers that parent/ teacher will have to assign and guide child to attempt after the test has been completed.

Grading: This question type is not graded on this system and will not affect the final score as it was designed in such a way that it requires manual assistance.

Question Type: Essay
Date Added: Sat 2nd Oct 2021
Last Modified: N/A
QID#: 29,206,487

Correctly answered feedback

To prevent water from evaporating so that the decrease in the amount of water is only due to the plant taking it in.

Incorrectly answered feedback

To prevent water from evaporating so that the decrease in the amount of water is only due to the plant taking it in.

[Answers](#) | [Edit](#) | [Duplicate](#) | [Used In](#) | [Reorder](#)

[Remove From Test](#)

Question 30

Primary 6 Science » Primary 6 Science (Term 2)

0 pts

Sean carried out an experiment to find out how the amount of light shining on a plant affects the amount of water it takes in.

The diagram below shows the set-ups of his experiment.

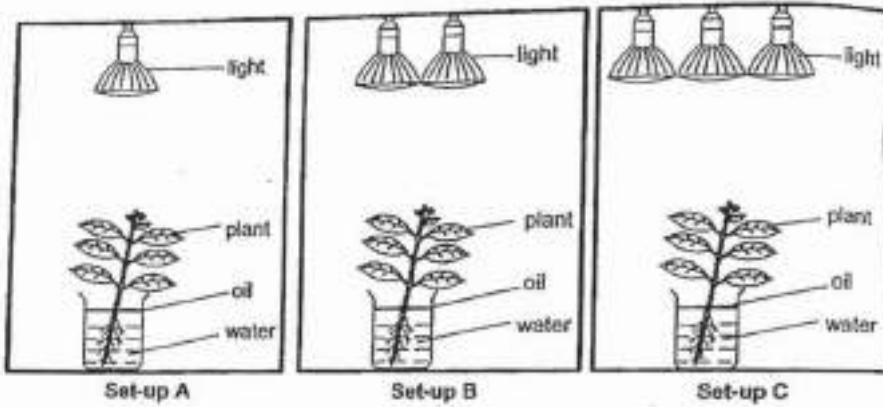

He left the set-ups in the same room and recorded the amount of water left in each beaker after four days.

	Set-up A	Set-up B	Set-up C
Amount of water at the start of the experiment (mℓ)	200	200	200
Amount of water at the end of the experiment (mℓ)	190	184	171

Explain why set-up C has the least amount of water left after 4 days. (2 marks)

This question is designed for extended answers that parent/ teacher will have to assign and guide child to attempt after the test has been completed.

Grading: This question type is not graded on this system and will not affect the final score as it was designed in such a way that it requires manual assistance.

Question Type: Essay
Date Added: Sat 2nd Oct 2021
Last Modified: N/A
QID#: 29,206,501

Correctly answered feedback

As set-up C had the most amount of light, it carried out the most photosynthesis, so it needed the most amount of water to do so, so it had the least amount of water left after 4 days.

Incorrectly answered feedback

As set-up C had the most amount of light, it carried out the most photosynthesis, so it needed the most amount of water to do so, so it had the least amount of water left after 4 days.

[Answers](#) | [Edit](#) | [Duplicate](#) | [Used In](#) | [Reorder](#)

[Remove From Test](#)

Question 31

Primary 6 Science » Primary 6 Science (Term 2)

0 pts

Sean carried out an experiment to find out how the amount of light shining on a plant affects the amount of water it takes in.

The diagram below shows the set-ups of his experiment.

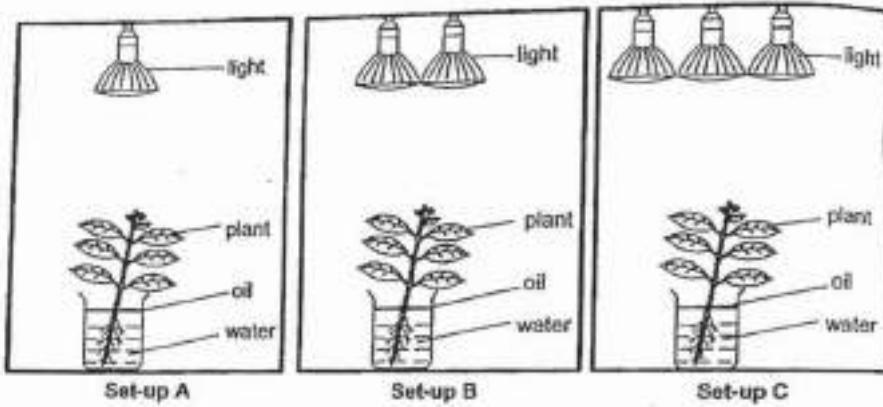

He left the set-ups in the same room and recorded the amount of water left in each beaker after four days.

	Set-up A	Set-up B	Set-up C
Amount of water at the start of the experiment (mℓ)	200	200	200
Amount of water at the end of the experiment (mℓ)	190	184	171

Sean then covered each set-up with a box and placed a sensor to measure the amount of oxygen released by each plant.

The graph below shows the results for the amount of oxygen released for set-up C.

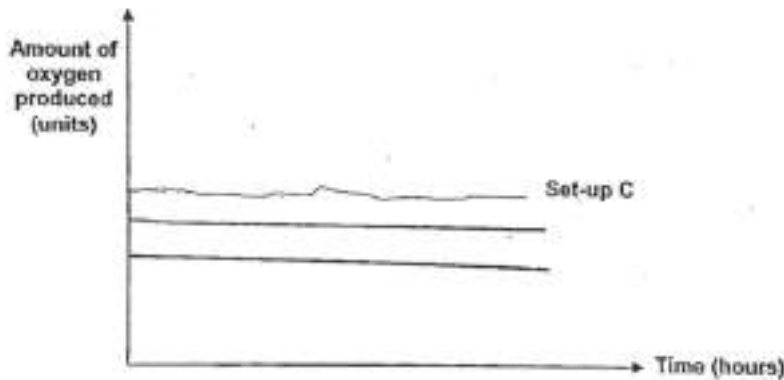

In the graph above, draw and label the results for set-ups A and B. (1 mark)

This question is designed for extended answers that parent/ teacher will have to assign and guide child to attempt after the test has been completed.

Grading: This question type is not graded on this system and will not affect the final score as it was designed in such a way that it requires manual assistance.

Question Type: Essay
 Date Added: Sat 2nd Oct 2021
 Last Modified: N/A
 QID#: 29,206,550

Correctly answered feedback

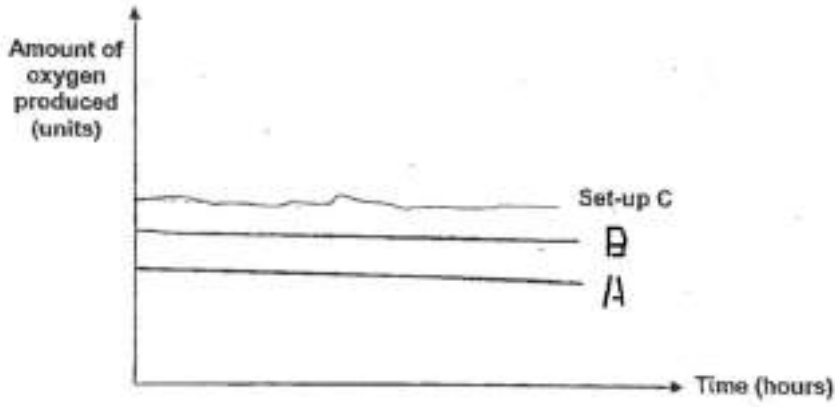

Incorrectly answered feedback

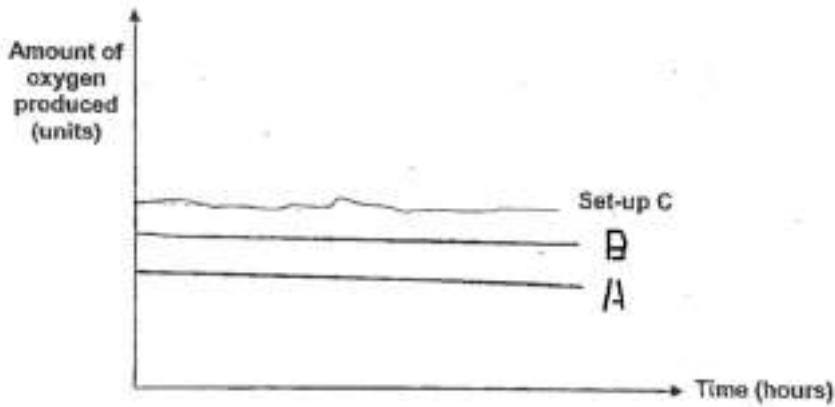

[Answers](#) | [Edit](#) | [Duplicate](#) | [Used In](#) | [Reorder](#)

[Remove From Test](#)

Question 32

Primary 6 Science » Primary 6 Science (Term 2)

0 pts

Jim conducted an experiment to find out how the size of food affected how fast the food is digested. He placed some meat into each of the set-ups, P, Q and R, as shown below. He cut the meat into two pieces for set-up Q and four pieces for set-up R. He then placed the meat into equal volume of digestive juice X, as shown in the diagram below.

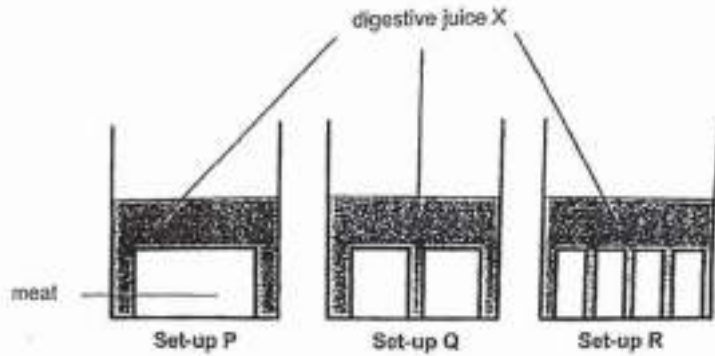

After 30 minutes, he recorded the results in the table below:

Set-up	Total mass of meat (g)	
	At the start of the experiment	After 30 minutes
P	102	92
Q	95	83
R	91	76

What should Jim do to ensure that his experiment is a fair test? (1 mark)

This question is designed for extended answers that parent/ teacher will have to assign and guide child to attempt after the test has been completed.

Grading: This question type is not graded on this system and will not affect the final score as it was designed in such a way that it requires manual assistance.

Question Type: Essay
Date Added: Sat 2nd Oct 2021
Last Modified: N/A
QID#: 29,206,562

Correctly answered feedback

Jim should make the amount of meat at first the same and change only the exposed surface area of food.

Incorrectly answered feedback

Jim should make the amount of meat at first the same and change only the exposed surface area of food.

[Answers](#) | [Edit](#) | [Duplicate](#) | [Used In](#) | [Reorder](#)

[Remove From Test](#)

Question 33

Primary 6 Science » Primary 6 Science (Term 2)

0 pts

Jim conducted an experiment to find out how the size of food affected how fast the food is digested. He placed some meat into each of the set-ups, P, Q and R, as shown below. He cut the meat into two pieces for set-up Q and four pieces for set-up R. He then placed the meat into equal volume of digestive juice X, as shown in the diagram below.

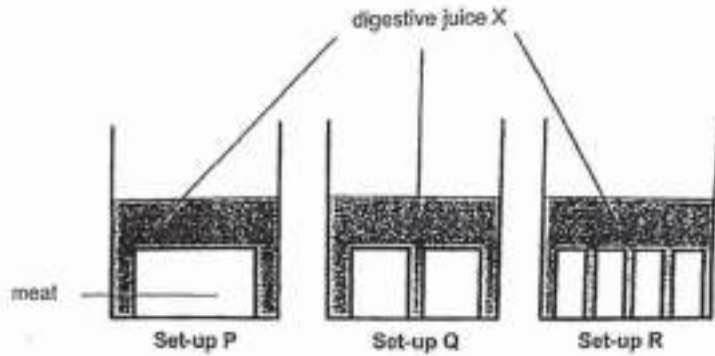

After 30 minutes, he recorded the results in the table below.

Set-up	Total mass of meat (g)	
	At the start of the experiment	After 30 minutes
P	102	92
Q	95	83
R	91	76

Explain how digestive juices helps in the digestion process. (1 mark)

This question is designed for extended answers that parent/ teacher will have to assign and guide child to attempt after the test has been completed.

Grading: This question type is not graded on this system and will not affect the final score as it was designed in such a way that it requires manual assistance.

Question Type: Essay
Date Added: Sat 2nd Oct 2021
Last Modified: N/A
QID#: 29,206,569

Correctly answered feedback

Digestive juices help to make the food into simpler substances.

Incorrectly answered feedback

Digestive juices help to make the food into simpler substances.

[Answers](#) | [Edit](#) | [Duplicate](#) | [Used In](#) | [Reorder](#)

[Remove From Test](#)

Question 34

Primary 6 Science » Primary 6 Science (Term 2)

0 pts

Jim conducted an experiment to find out how the size of food affected how fast the food is digested. He placed some meat into each of the set-ups, P, Q and R, as shown below. He cut the meat into two pieces for set-up Q and four pieces for set-up R. He then placed the meat into equal volume of digestive juice X, as shown in the diagram below.

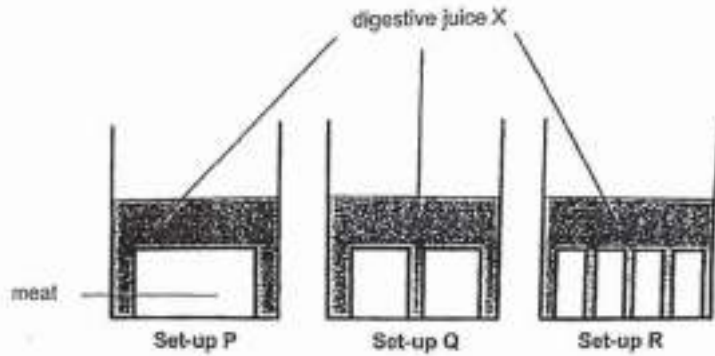

After 30 minutes, he recorded the results in the table below:

Set-up	Total mass of meat (g)	
	At the start of the experiment	After 30 minutes
P	102	92
Q	95	83
R	91	76

The graph below show how the amount of undigested food changes as it passes through the parts of Jim's digestive system when he chews his food before swallowing.

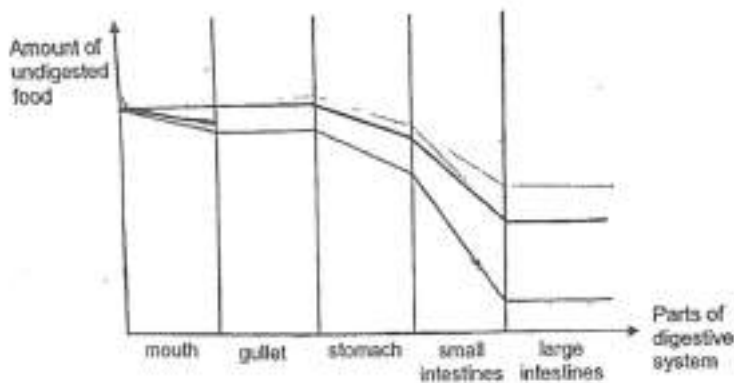

In the graph above, draw how the amount of undigested food changes if Jim does not chew before swallowing. [2]

This question is designed for extended answers that parent/ teacher will have to assign and guide child to attempt after the test has been completed.

Grading: This question type is not graded on this system and will not affect the final score as it was designed in such a way that it requires manual assistance.

Question Type: Essay
 Date Added: Sat 2nd Oct 2021
 Last Modified: N/A
 QID#: 29,206,578

Correctly answered feedback

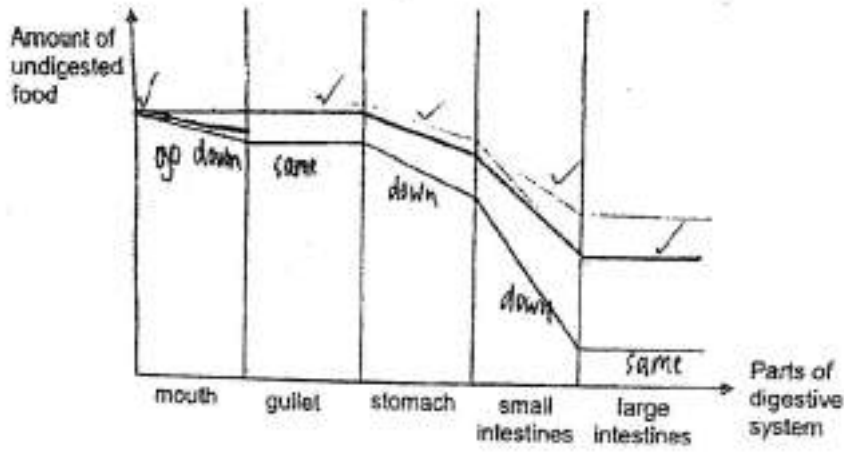

Incorrectly answered feedback

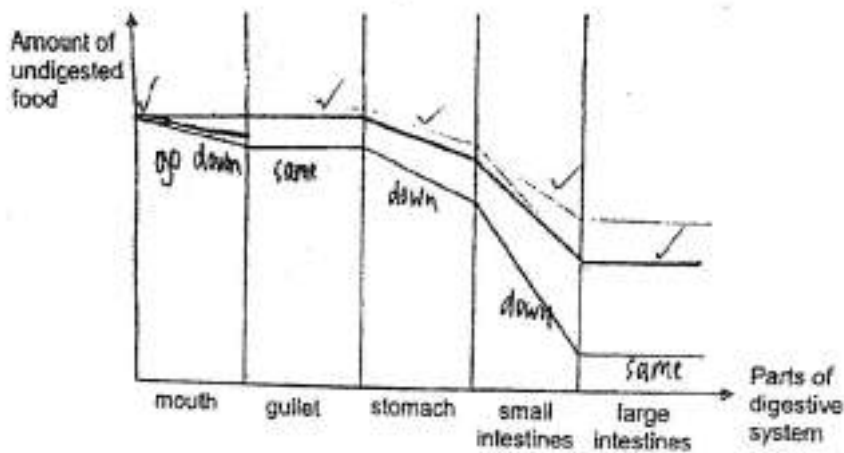

[Answers](#) |
 [Edit](#) |
 [Duplicate](#) |
 [Used In](#) |
 [Reorder](#)

[Remove From Test](#)

Question 35

Primary 6 Science » Primary 6 Science (Term 2)

1 pt

The diagram below shows a plant cell.

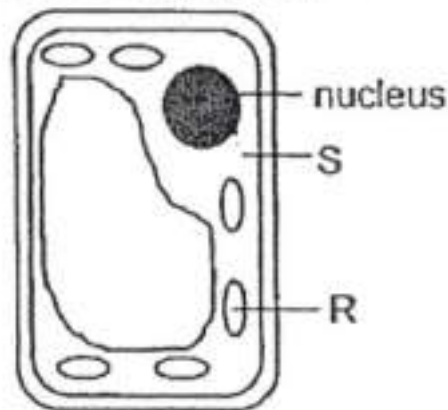

In which part of a plant are you most likely to find the cell above? (1 mark)

Accepted answers:

✓ Leaves

Question Type: Free Text
Date Added: Sat 2nd Oct 2021
Last Modified: N/A
QID#: 29,206,587

[Answers](#) |
 [Edit](#) |
 [Duplicate](#) |
 [Used In](#) |
 [Reorder](#)

[Remove From Test](#)

Question 36

Primary 6 Science » Primary 6 Science (Term 2)

0 pts

The diagram below shows a plant cell.

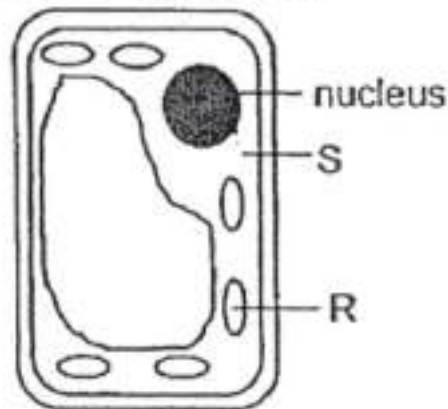

State the function of part S. (1 mark)

This question is designed for extended answers that parent/ teacher will have to assign and guide child to attempt after the test has been completed.

Grading: This question type is not graded on this system and will not affect the final score as it was designed in such a way that it requires manual assistance.

Question Type: Essay
Date Added: Sat 2nd Oct 2021
Last Modified: N/A
QID#: 29,206,591

Correctly answered feedback

Part S is a place where other cell parts take place.

Incorrectly answered feedback

Part S is a place where other cell parts take place.

[Answers](#) |
 [Edit](#) |
 [Duplicate](#) |
 [Used In](#) |
 [Reorder](#)

[Remove From Test](#)

Question 37

Primary 6 Science » Primary 6 Science (Term 2)

0 pts

The diagram below shows a plant cell.

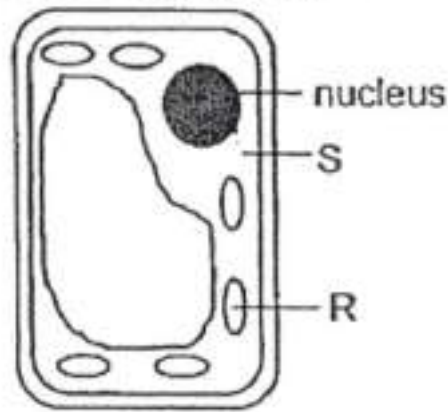

Explain why part R cannot be found in an animal cell. (1 mark)

This question is designed for extended answers that parent/ teacher will have to assign and guide child to attempt after the test has been completed.

Grading: This question type is not graded on this system and will not affect the final score as it was designed in such a way that it requires manual assistance.

Question Type: Essay
Date Added: Sat 2nd Oct 2021
Last Modified: N/A
QID#: 29,206,598

Correctly answered feedback

Part R is the chlorophyll and since animals cannot photosynthesise, part R cannot be found in an animal cell.

Incorrectly answered feedback

Part R is the chlorophyll and since animals cannot photosynthesise, part R cannot be found in an animal cell.

[Answers](#) | [Edit](#) | [Duplicate](#) | [Used In](#) | [Reorder](#)

[Remove From Test](#)

Question 38

Primary 6 Science » Primary 6 Science (Term 2)

2 pts

Sammy conducted an experiment where she heated three different materials with the same amount of heat for 30 minutes and recorded the results in the table as shown below.

Material	Temperature (°C)	
	At the start of the experiment	After 30 minutes
P	28	35
Q	28	50
R	28	80

She then set up another experiment as shown in the diagram below and placed it under the sun for one hour.

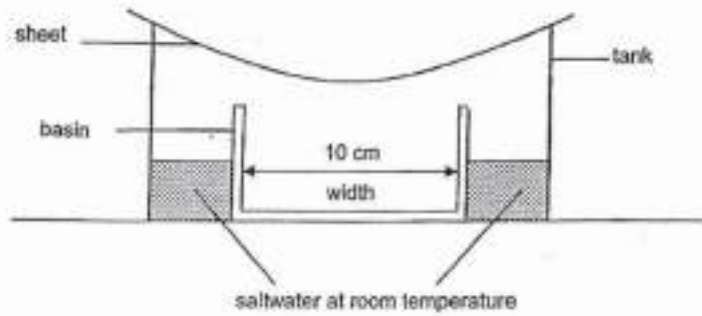

In the blanks below, fill in the material, P, Q, or R, that she should use for each part of her setup so that she can collect the most amount of pure water in the basin. (She can use the same material more than once.)

Clue	Match
Sheet: Material _____	P
Points: +1 -0	
Tank: Material _____	R
Points: +1 -0	
<i>Incorrect match option</i>	Q

Question Type: Matching
Shuffle Mode: Shuffle Matches Only
Date Added: Sat 2nd Oct 2021
Last Modified: N/A
QID#: 29,206,617

[Answers](#) | [Edit](#) | [Duplicate](#) | [Used In](#) | [Reorder](#)

[Remove From Test](#)

Question 39

Primary 6 Science » Primary 6 Science (Term 2)

0 pts

Sammy conducted an experiment where she heated three different materials with the same amount of heat for 30 minutes and recorded the results in the table as shown below.

Material	Temperature (°C)	
	At the start of the experiment	After 30 minutes
P	28	35
Q	28	50
R	28	80

She then set up another experiment as shown in the diagram below and placed it under the sun for one hour.

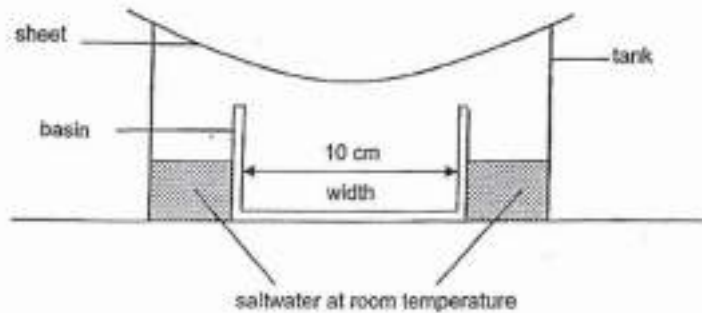

Suggest two other modifications to the set-up Sammy can make to collect more pure water in the basin after six hours. (2 marks)

This question is designed for extended answers that parent/ teacher will have to assign and guide child to attempt after the test has been completed.

Grading: This question type is not graded on this system and will not affect the final score as it was designed in such a way that it requires manual assistance.

Question Type: Essay
Date Added: Sat 2nd Oct 2021
Last Modified: N/A
QID#: 29,206,635

Correctly answered feedback

- i) Reduce the width of the basin.
- ii) Put ice on the sheet.

Incorrectly answered feedback

- i) Reduce the width of the basin.
- ii) Put ice on the sheet.

[Answers](#) | [Edit](#) | [Duplicate](#) | [Used In](#) | [Reorder](#)

[Remove From Test](#)

Question 40

Primary 6 Science » Primary 6 Science (Term 2)

0 pts

John was standing in an air-conditioned room as shown in the diagram below.

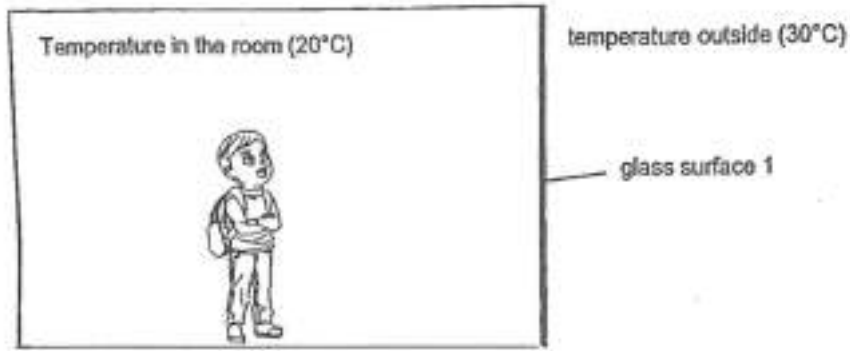

John noticed that there were water droplets on the glass surface.

Explain how and where the water droplets were formed. (2 marks)

This question is designed for extended answers that parent/ teacher will have to assign and guide child to attempt after the test has been completed.

Grading: This question type is not graded on this system and will not affect the final score as it was designed in such a way that it requires manual assistance.

Question Type: Essay
Date Added: Sat 2nd Oct 2021
Last Modified: N/A
QID#: 29,206,649

Correctly answered feedback

When the water vapour from the surroundings outside the room came into contact with the cooler glass surface, it lost heat to it and condensed to form water droplets.

Incorrectly answered feedback

When the water vapour from the surroundings outside the room came into contact with the cooler glass surface, it lost heat to it and condensed to form water droplets.

[Answers](#) | [Edit](#) | [Duplicate](#) | [Used In](#) | [Reorder](#)

[Remove From Test](#)

Question 41

Primary 6 Science » Primary 6 Science (Term 2)

0 pts

John was standing in an air-conditioned room as shown in the diagram below.

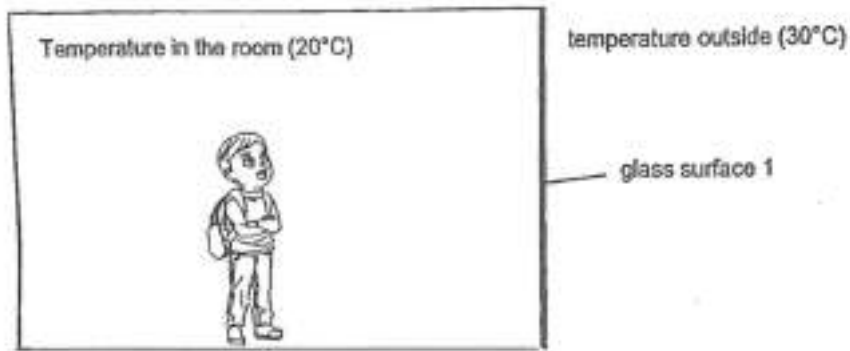

John noticed that there were water droplets on the glass surface.

John replaced the original window with a double-glazed window of the same material, as shown in the diagram below.

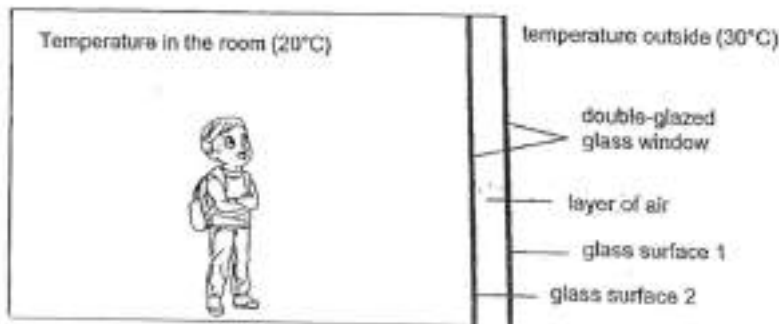

Explain why surface 1 of the double-glazed window did not have as much water droplets on it as in part (a). [2]

This question is designed for extended answers that parent/ teacher will have to assign and guide child to attempt after the test has been completed.

Grading: This question type is not graded on this system and will not affect the final score as it was designed in such a way that it requires manual assistance.

Question Type: Essay
Date Added: Sat 2nd Oct 2021
Last Modified: N/A
QID#: 29,206,676

Correctly answered feedback

As there is a layer of air in between glass surface 2 and, air will slow down heat loss from the glass surface to the air in the room so the temperature of the glass surface is lower. Resulting in lesser condensation and lesser water droplets are formed.

Incorrectly answered feedback

As there is a layer of air in between glass surface 2 and, air will slow down heat loss from the glass surface to the air in the room so the temperature of the glass surface is lower. Resulting in lesser condensation and lesser water droplets are formed.

[Answers](#) | [Edit](#) | [Duplicate](#) | [Used In](#) | [Reorder](#)

[Remove From Test](#)

Question 42

Primary 6 Science » Primary 6 Science (Term 2)

0 pts

Xinyi is given the following items.



a roll of sticky tape



a plastic toy car

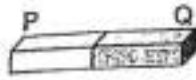

a bar magnet



a steel rod

Using only the given items above, state how Xinyi could make the toy car move forward without pushing or pulling it. (2 marks)

Step 1: _____

Step 2: _____

This question is designed for extended answers that parent/ teacher will have to assign and guide child to attempt after the test has been completed.

Grading: This question type is not graded on this system and will not affect the final score as it was designed in such a way that it requires manual assistance.

Question Type: Essay
Date Added: Sat 2nd Oct 2021
Last Modified: Sat 2nd Oct 2021
QID#: 29,206,742

Correctly answered feedback

She can use the sticky tape to tape the bar magnet on the front of the car. After that, bring the steel rod close to the magnet and the car will move.

She can use the sticky tape to tape the steel rod on the front of the car. After that, bring the magnet close to the rod and the car will move.

Incorrectly answered feedback

She can use the sticky tape to tape the bar magnet on the front of the car. After that, bring the steel rod close to the magnet and the car will move.

She can use the sticky tape to tape the steel rod on the front of the car. After that, bring the magnet close to the rod and the car will move.

[Answers](#) | [Edit](#) | [Duplicate](#) | [Used In](#) | [Reorder](#)

[Remove From Test](#)

Question 43

Primary 6 Science » Primary 6 Science (Term 2)

0 pts

Xinyi is given the following items.



a roll of sticky tape



a plastic toy car

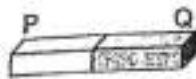

a bar magnet



a steel rod

What would be observed if a lighter toy car is used? (1 mark)

This question is designed for extended answers that parent/ teacher will have to assign and guide child to attempt after the test has been completed.

Grading: This question type is not graded on this system and will not affect the final score as it was designed in such a way that it requires manual assistance.

Question Type: Essay
Date Added: Sat 2nd Oct 2021
Last Modified: N/A
QID#: 29,206,766

Correctly answered feedback

The car would move faster.

Incorrectly answered feedback

The car would move faster.

[Answers](#) | [Edit](#) | [Duplicate](#) | [Used In](#) | [Reorder](#)

[Remove From Test](#)

Question 44

Primary 6 Science » Primary 6 Science (Term 2)

0 pts

Xinyi is given the following items.



a roll of sticky tape



a plastic toy car

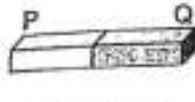

a bar magnet



a steel rod

Xinyi replaced the steel rod with another bar magnet.

What should Xinyi do in order to make the toy car move forward? (1 mark)

This question is designed for extended answers that parent/ teacher will have to assign and guide child to attempt after the test has been completed.

Grading: This question type is not graded on this system and will not affect the final score as it was designed in such a way that it requires manual assistance.

Question Type: Essay
Date Added: Sat 2nd Oct 2021
Last Modified: N/A
QID#: 29,206,772

Correctly answered feedback

Xinyi should put a magnet's North pole facing out on the back of the car and then use the North pole of the other magnet to repel it.

Incorrectly answered feedback

Xinyi should put a magnet's North pole facing out on the back of the car and then use the North pole of the other magnet to repel it.

[Answers](#) | [Edit](#) | [Duplicate](#) | [Used In](#) | [Reorder](#)

[Remove From Test](#)

Question 45

Primary 6 Science » Primary 6 Science (Term 2)

0 pts

Peter carried out an experiment in a park as shown in the diagram below.

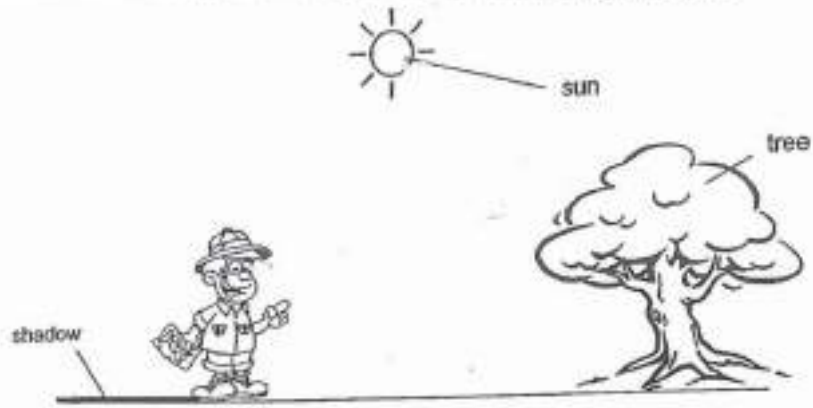

In the diagram above, draw light rays to show how Peter is able to see the tree. (1 mark)

This question is designed for extended answers that parent/ teacher will have to assign and guide child to attempt after the test has been completed.

Grading: This question type is not graded on this system and will not affect the final score as it was designed in such a way that it requires manual assistance.

Question Type: Essay
Date Added: Sat 2nd Oct 2021
Last Modified: N/A
QID#: 29,206,785

Correctly answered feedback

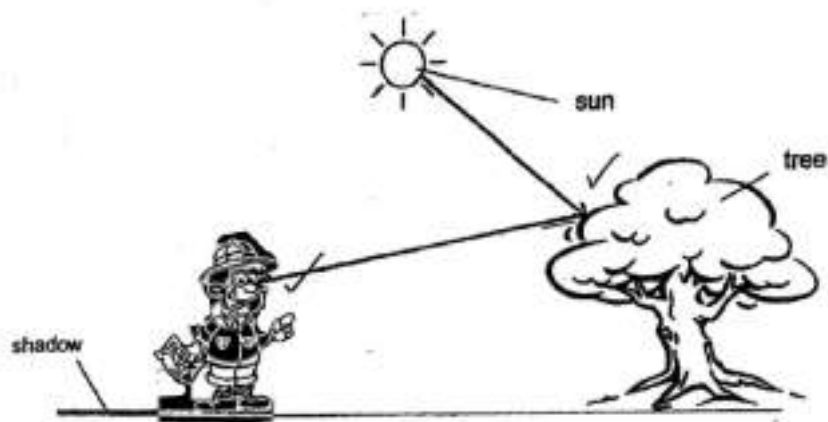

Incorrectly answered feedback

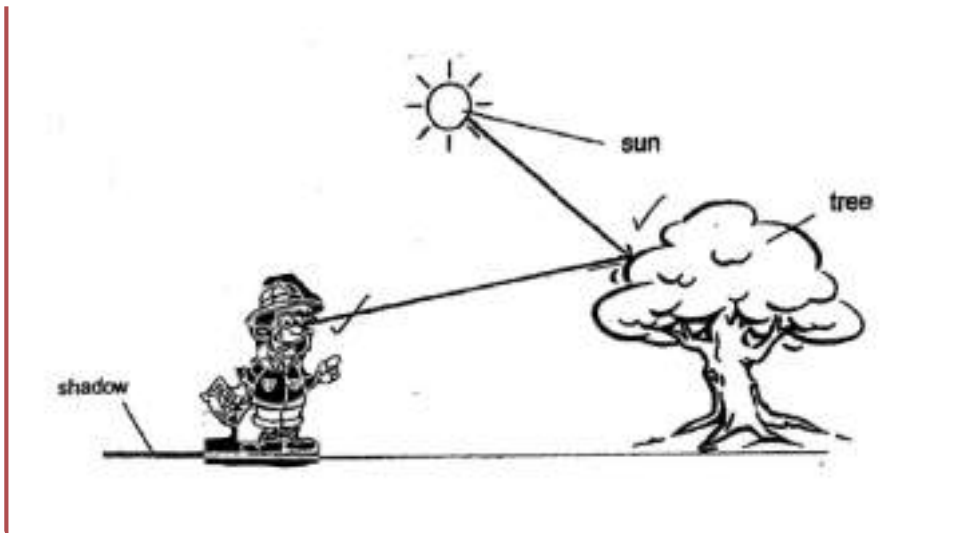

[Answers](#) |
 [Edit](#) |
 [Duplicate](#) |
 [Used In](#) |
 [Reorder](#)

[Remove From Test](#)

Question 46

Primary 6 Science » Primary 6 Science (Term 2)

0 pts

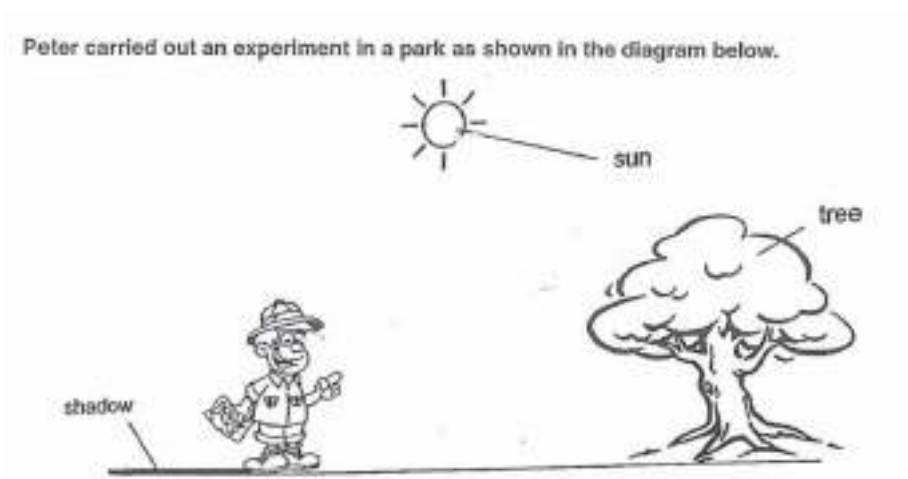

Explain how wearing a hat on a bright day helps to protect Peter's eyes. (1 mark)

This question is designed for extended answers that parent/ teacher will have to assign and guide child to attempt after the test has been completed.

Grading: This question type is not graded on this system and will not affect the final score as it was designed in such a way that it requires manual assistance.

Question Type: Essay
Date Added: Sat 2nd Oct 2021
Last Modified: N/A
QID#: 29,206,803

Correctly answered feedback

The hat would block most of the light from the sun from entering Peter's eye.

Incorrectly answered feedback

The hat would block most of the light from the sun from entering Peter's eye.

[Answers](#) |
 [Edit](#) |
 [Duplicate](#) |
 [Used In](#) |
 [Reorder](#)

[Remove From Test](#)

Question 47

Primary 6 Science » Primary 6 Science (Term 2)

0 pts

Peter carried out an experiment in a park as shown in the diagram below.

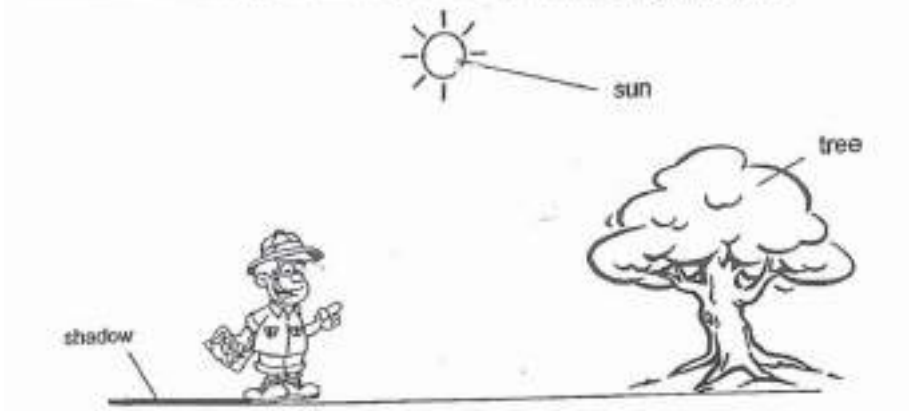

What will happen to the size of Peter's shadow as he moves towards the tree? (1 mark)

This question is designed for extended answers that parent/ teacher will have to assign and guide child to attempt after the test has been completed.

Grading: This question type is not graded on this system and will not affect the final score as it was designed in such a way that it requires manual assistance.

Question Type: Essay
Date Added: Sat 2nd Oct 2021
Last Modified: N/A
QID#: 29,206,813

Correctly answered feedback

It would become shorter and then it would get bigger.

Incorrectly answered feedback

It would become shorter and then it would get bigger.

[Answers](#) | [Edit](#) | [Duplicate](#) | [Used In](#) | [Reorder](#)

[Remove From Test](#)

Question 48

Primary 6 Science » Primary 6 Science (Term 2)

0 pts

Peter carried out an experiment in a park as shown in the diagram below.

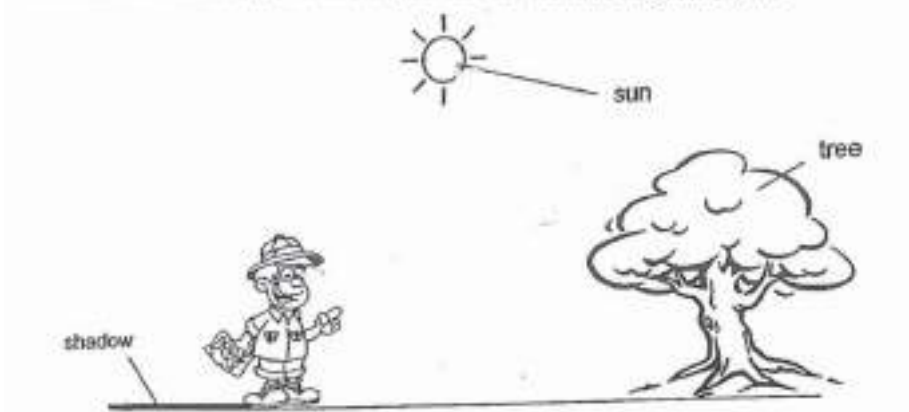

State two properties of light that caused the shadow to be formed. (1 mark)

This question is designed for extended answers that parent/ teacher will have to assign and guide child to attempt after the test has been completed.

Grading: This question type is not graded on this system and will not affect the final score as it was designed in such a way that it requires manual assistance.

Question Type: Essay
Date Added: Sat 2nd Oct 2021
Last Modified: N/A
QID#: 29,206,824

Correctly answered feedback

- i) Light travels in a straight line.
- ii) Light can be blocked by objects.

Incorrectly answered feedback

- i) Light travels in a straight line.
- ii) Light can be blocked by objects.

[Answers](#) | [Edit](#) | [Duplicate](#) | [Used In](#) | [Reorder](#)

[Remove From Test](#)

Question 49

Primary 6 Science » Primary 6 Science (Term 2)

1 pt

Yusri made a toy as shown in the diagram below. He pumped 50 cm^3 of air into the balloon and released it. The distance moved by the toy over the floor, d , was then measured.

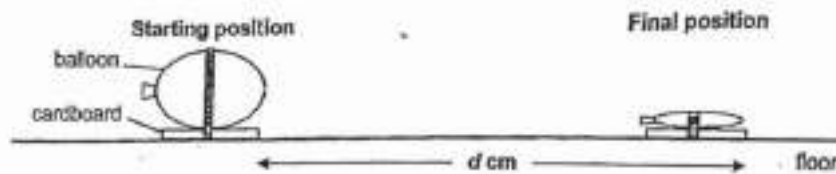

Yusri repeated the experiment by pumping different amounts of air into the balloon. The results of his experiment are shown in the graph below.

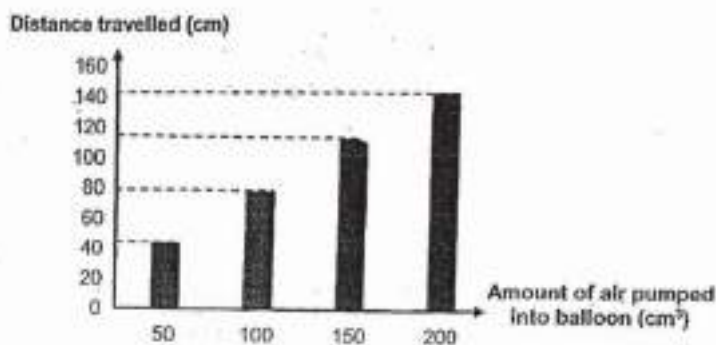

State the force that had caused the toy to stop moving at the final position.

Accepted answers:

- ✓ Frictional force

Question Type: Free Text
Date Added: Sat 2nd Oct 2021
Last Modified: N/A
QID#: 29,206,840

[Answers](#) |
 [Edit](#) |
 [Duplicate](#) |
 [Used In](#) |
 [Reorder](#)

[Remove From Test](#)

Question 50

Primary 6 Science » Primary 6 Science (Term 2)

0 pts

Yusri made a toy as shown in the diagram below. He pumped 50 cm^3 of air into the balloon and released it. The distance moved by the toy over the floor, d , was then measured.

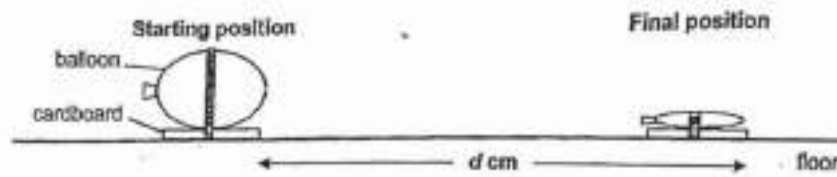

Yusri repeated the experiment by pumping different amounts of air into the balloon. The results of his experiment are shown in the graph below.

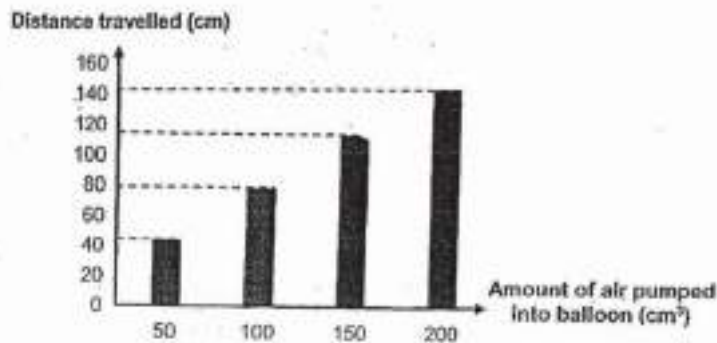

What is the relationship between the amount of air pumped into the balloon and the distance travelled by the toy across the floor? (1 mark)

This question is designed for extended answers that parent/ teacher will have to assign and guide child to attempt after the test has been completed.

Grading: This question type is not graded on this system and will not affect the final score as it was designed in such a way that it requires manual assistance.

Question Type: Essay
Date Added: Sat 2nd Oct 2021
Last Modified: N/A
QID#: 29,206,858

Correctly answered feedback

The larger the amount of air pumped into the balloon, the further the distance travelled by the toy across the floor.

Incorrectly answered feedback

The larger the amount of air pumped into the balloon, the further the distance travelled by the toy across the floor.

[Answers](#) |
 [Edit](#) |
 [Duplicate](#) |
 [Used In](#) |
 [Reorder](#)

[Remove From Test](#)

Question 51

Primary 6 Science » Primary 6 Science (Term 2)

0 pts

Yusri made a toy as shown in the diagram below. He pumped 50 cm^3 of air into the balloon and released it. The distance moved by the toy over the floor, d , was then measured.

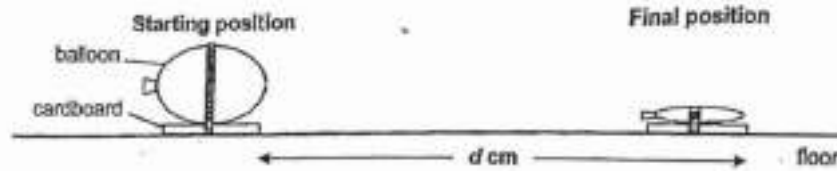

Yusri repeated the experiment by pumping different amounts of air into the balloon. The results of his experiment are shown in the graph below.

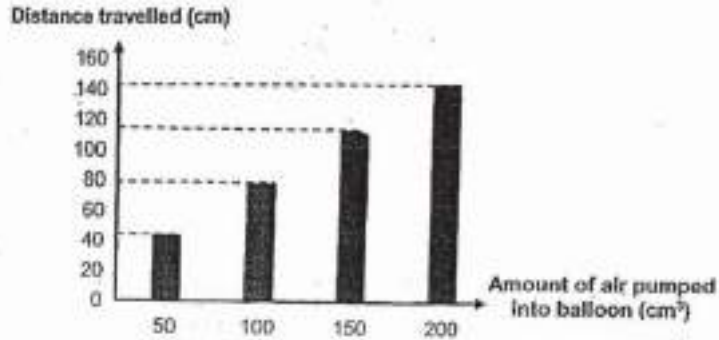

Suggest how Yusri could increase the reliability of his results. (1 mark)

This question is designed for extended answers that parent/ teacher will have to assign and guide child to attempt after the test has been completed.

Grading: This question type is not graded on this system and will not affect the final score as it was designed in such a way that it requires manual assistance.

Question Type: Essay
 Date Added: Sat 2nd Oct 2021
 Last Modified: N/A
 QID#: 29,206,866

Correctly answered feedback

Yusri could repeat the experiment 3 more times.

Incorrectly answered feedback

Yusri could repeat the experiment 3 more times.

[Answers](#) | [Edit](#) | [Duplicate](#) | [Used In](#) | [Reorder](#)

[Remove From Test](#)

Question 52

Primary 6 Science » Primary 6 Science (Term 2)

0 pts

Yusri made a toy as shown in the diagram below. He pumped 50 cm^3 of air into the balloon and released it. The distance moved by the toy over the floor, d , was then measured.



Yusri repeated the experiment by pumping different amounts of air into the balloon. The results of his experiment are shown in the graph below.

Distance travelled (cm)

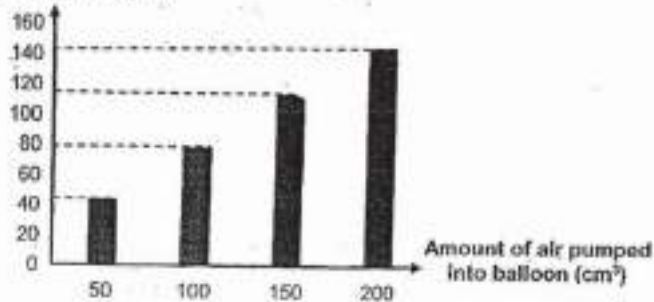

Yusri then repeated his experiment by placing the toy at the bottom of a ramp with a similar surface as the floor.

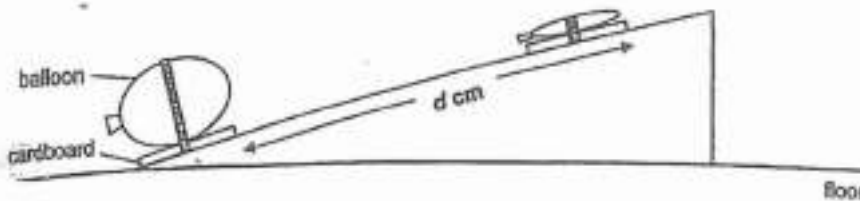

When 200 cm^3 of air was pumped into the balloon, would the toy now travel a shorter, longer, or same distance on the ramp than on the floor? Explain your answer in terms of forces. [2]

This question is designed for extended answers that parent/ teacher will have to assign and guide child to attempt after the test has been completed.

Grading: This question type is not graded on this system and will not affect the final score as it was designed in such a way that it requires manual assistance.

Question Type: Essay
 Date Added: Sat 2nd Oct 2021
 Last Modified: N/A
 QID#: 29,206,884

Correctly answered feedback

When 200 cm^3 of air was pumped into the balloon, the toy would travel a shorter distance on the ramp than on the floor. When it is travelling up the ramp, more force is required to push it up the ramp as it is going against gravity, making it harder to move upwards. So it would travel a shorter distance.

Incorrectly answered feedback

When 200 cm^3 of air was pumped into the balloon, the toy would travel a shorter distance on the ramp than on the floor. When it is travelling up the ramp, more force is required to push it up the ramp as it is going against gravity, making it harder to move upwards. So it would travel a shorter distance.

Question 53

Primary 6 Science » Primary 6 Science (Term 2)

0 pts

Mary used a dropper to take in liquid X from a beaker as shown in the set-up below. Mary squeezed the rubber handle of the dropper and then released it again to take in liquid X from the beaker.

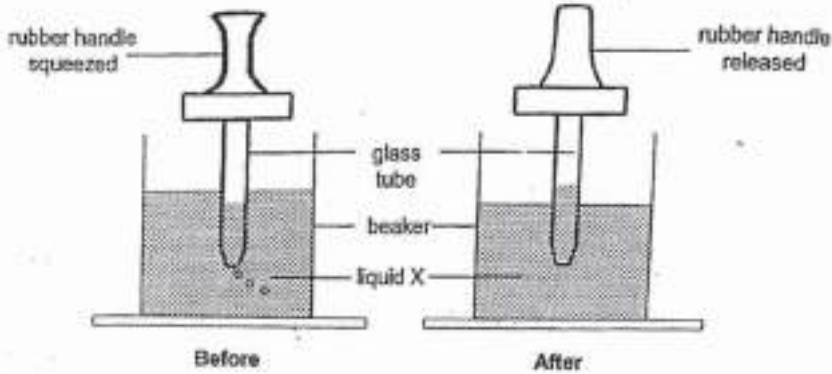

Explain how these actions enabled some of the liquid to enter the glass tube of the dropper. [2]

i) Squeezing the rubber handle: _____

ii) Releasing the rubber handle: _____

This question is designed for extended answers that parent/ teacher will have to assign and guide child to attempt after the test has been completed.

Grading: This question type is not graded on this system and will not affect the final score as it was designed in such a way that it requires manual assistance.

Question Type: Essay
Date Added: Sat 2nd Oct 2021
Last Modified: N/A
QID#: 29,206,890

Correctly answered feedback

- i) Removing the air from the glass tube.
- ii) Making liquid X enter the glass tube to occupy the space previously occupied by the air.

Incorrectly answered feedback

- i) Removing the air from the glass tube.
- ii) Making liquid X enter the glass tube to occupy the space previously occupied by the air.

Question 54

Primary 6 Science » Primary 6 Science (Term 2)

1 pt

Jaima created a toy using a bottle cap, ice-cream sticks and rubber bands as shown in the diagram below.

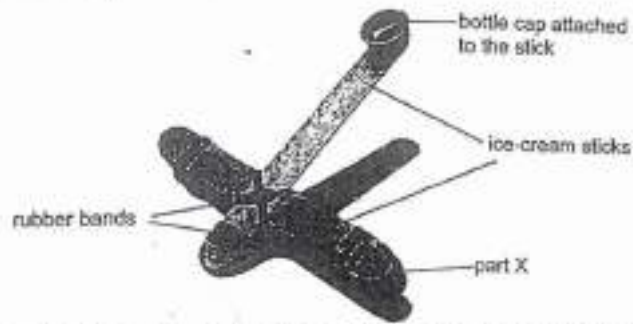

She placed a paper ball in the bottle cap, pushed the bottle cap downwards and released the bottle cap which launched the paper ball through the air.

She then made 3 other similar toys using different number of ice-cream sticks to make part X and repeated the experiment. Her results are shown in the table below.

Number of ice-cream sticks used to make part X	3	6	9	12
Distance moved by the paper ball (cm)	2	8	12	22

State the form of energy that the rubber bands possessed when the bottle cap was pushed down.

Accepted answers:

- ✓ Elastic potential energy

Question Type: Free Text
 Date Added: Sat 2nd Oct 2021
 Last Modified: N/A
 QID#: 29,206,895

[Answers](#) | [Edit](#) | [Duplicate](#) | [Used In](#) | [Reorder](#)

[Remove From Test](#)

Question 55

Primary 6 Science » Primary 6 Science (Term 2)

0 pts

Jaima created a toy using a bottle cap, ice-cream sticks and rubber bands as shown in the diagram below.

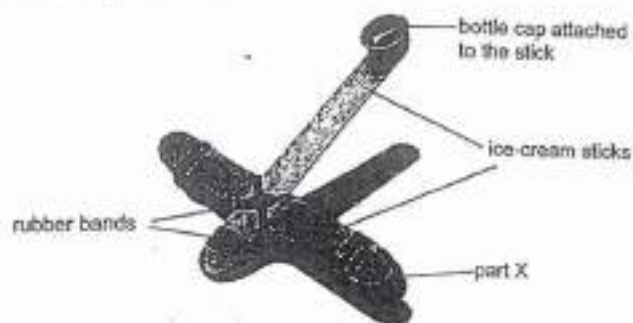

She placed a paper ball in the bottle cap, pushed the bottle cap downwards and released the bottle cap which launched the paper ball through the air.

She then made 3 other similar toys using different number of ice-cream sticks to make part X and repeated the experiment. Her results are shown in the table below.

Number of ice-cream sticks used to make part X	3	6	9	12
Distance moved by the paper ball (cm)	2	8	12	22

State the relationship between the number of ice-cream sticks used to make part X and the distance moved by the paper ball. (1 mark)

This question is designed for extended answers that parent/ teacher will have to assign and guide child to attempt after the test has been completed.

Grading: This question type is not graded on this system and will not affect the final score as it was designed in such a way that it requires manual assistance.

Question Type: Essay
Date Added: Sat 2nd Oct 2021
Last Modified: N/A
QID#: 29,206,902

Correctly answered feedback

The more the number of ice cream sticks used to make part X, the further the distance moved by the paper ball.

Incorrectly answered feedback

The more the number of ice cream sticks used to make part X, the further the distance moved by the paper ball.

[Answers](#) | [Edit](#) | [Duplicate](#) | [Used In](#) | [Reorder](#)

[Remove From Test](#)

Question 56

Primary 6 Science » Primary 6 Science (Term 2)

0 pts

Jaime created a toy using a bottle cap, ice-cream sticks and rubber bands as shown in the diagram below.

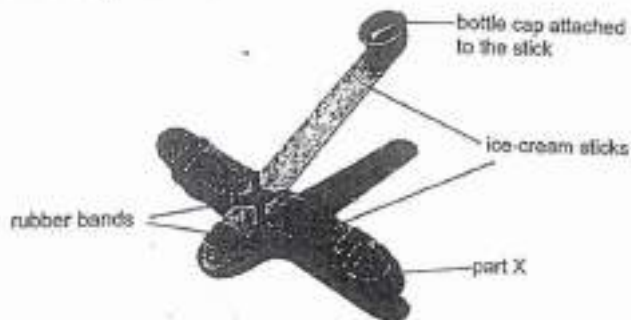

She placed a paper ball in the bottle cap, pushed the bottle cap downwards and released the bottle cap which launched the paper ball through the air.

She then made 3 other similar toys using different number of ice-cream sticks to make part X and repeated the experiment. Her results are shown in the table below.

Number of ice-cream sticks used to make part X	3	6	9	12
Distance moved by the paper ball (cm)	2	8	12	22

Explain why it is important for her to use ice cream sticks of the same thickness for each toy. (1 mark)

This question is designed for extended answers that parent/ teacher will have to assign and guide child to attempt after the test has been completed.

Grading: This question type is not graded on this system and will not affect the final score as it was designed in such a way that it requires manual assistance.

Question Type: Essay
Date Added: Sat 2nd Oct 2021
Last Modified: N/A
QID#: 29,206,909

Correctly answered feedback

To ensure that the only changed variable is the number of ice cream sticks so the results are a fair test.

Incorrectly answered feedback

To ensure that the only changed variable is the number of ice cream sticks so the results are a fair test.

Answers | Edit | Duplicate | Used In | Reorder

Remove From Test

Question 57

Primary 6 Science » Primary 6 Science (Term 2)

0 pts

Aidil carried a heavy backpack and skated down a ramp without pushing off. He noticed that when he reached point X, there was a slight pause before his skateboard rolled backwards.

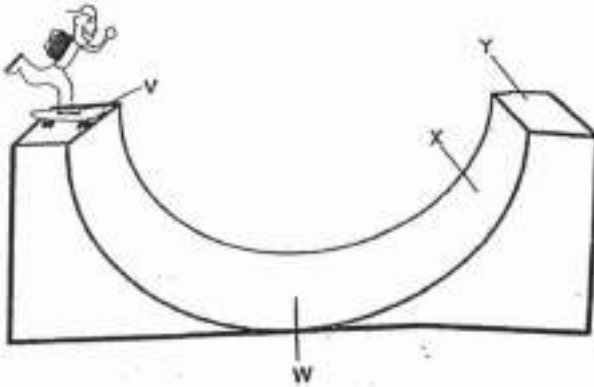

State the main energy conversions from point V to point X.

[1]

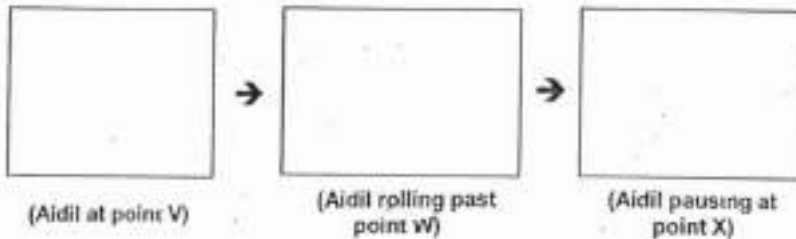

This question is designed for extended answers that parent/ teacher will have to assign and guide child to attempt after the test has been completed.

Grading: This question type is not graded on this system and will not affect the final score as it was designed in such a way that it requires manual assistance.

Question Type: Essay
 Date Added: Sat 2nd Oct 2021
 Last Modified: N/A
 QID#: 29,206,935

Correctly answered feedback

Gravitational potential energy -----> Kinetic energy -----> Gravitational potential energy

Incorrectly answered feedback

Gravitational potential energy -----> Kinetic energy -----> Gravitational potential energy

Answers | Edit | Duplicate | Used In | Reorder

Remove From Test

Question 58

Primary 6 Science » Primary 6 Science (Term 2)

0 pts

Aidil carried a heavy backpack and skated down a ramp without pushing off. He noticed that when he reached point X, there was a slight pause before his skateboard rolled backwards.

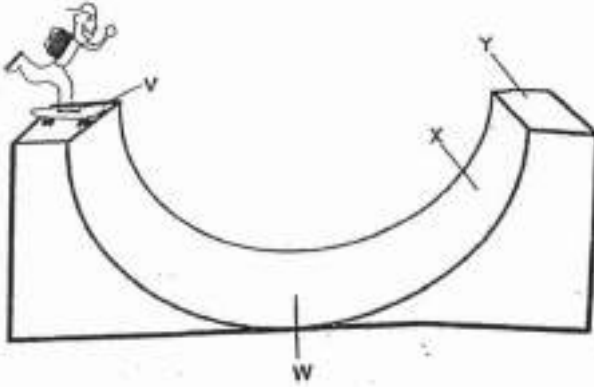

Explain why he still could not reach point Y. (2 marks)

This question is designed for extended answers that parent/ teacher will have to assign and guide child to attempt after the test has been completed.

Grading: This question type is not graded on this system and will not affect the final score as it was designed in such a way that it requires manual assistance.

Question Type: Essay
Date Added: Sat 2nd Oct 2021
Last Modified: N/A
QID#: 29,206,953

Correctly answered feedback

When he was moving down the ramp, some of the kinetic energy was converted to heat and sound energy, so not 100% of it was converted to kinetic energy so it could not reach point Y.

Incorrectly answered feedback

When he was moving down the ramp, some of the kinetic energy was converted to heat and sound energy, so not 100% of it was converted to kinetic energy so it could not reach point Y.

[Answers](#) | [Edit](#) | [Duplicate](#) | [Used In](#) | [Reorder](#)

[Remove From Test](#)

Question 59

Primary 6 Science » Primary 6 Science (Term 2)

0 pts

Aidil carried a heavy backpack and skated down a ramp without pushing off. He noticed that when he reached point X, there was a slight pause before his skateboard rolled backwards.

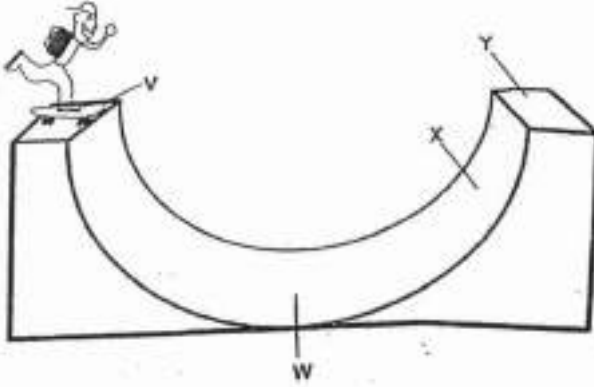

Without using a lubricant, suggest one change that will allow him to reach point Y. (1 mark)

This question is designed for extended answers that parent/ teacher will have to assign and guide child to attempt after the test has been completed.

Grading: This question type is not graded on this system and will not affect the final score as it was designed in such a way that it requires manual assistance.

Question Type: Essay
Date Added: Sat 2nd Oct 2021
Last Modified: N/A
QID#: 29,206,961

Correctly answered feedback

He could push it off at point V.

Incorrectly answered feedback

He could push it off at point V.

[Answers](#) | [Edit](#) | [Duplicate](#) | [Used In](#) | [Reorder](#)

[Remove From Test](#)

Question 60

Primary 6 Science » Primary 6 Science (Term 2)

0 pts

The diagram below shows parts of a torch.

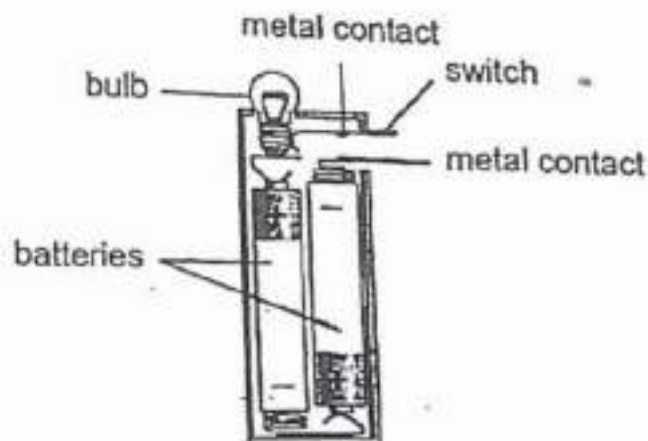

Draw a circuit diagram to represent the electrical circuit in the torch above. (2 marks)

This question is designed for extended answers that parent/ teacher will have to assign and guide child to attempt after the test has been completed.

Grading: This question type is not graded on this system and will not affect the final score as it was designed in such a way that it requires manual assistance.

Question Type: Essay
Date Added: Sat 2nd Oct 2021
Last Modified: N/A
QID#: 29,206,976

Correctly answered feedback

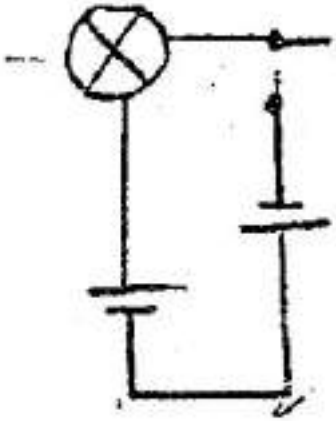

Incorrectly answered feedback

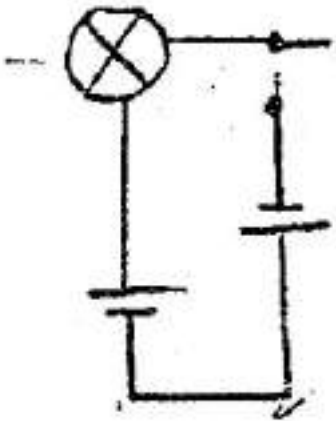

[Answers](#) | [Edit](#) | [Duplicate](#) | [Used In](#) | [Reorder](#)

[Remove From Test](#)

Question 61

Primary 6 Science » Primary 6 Science (Term 2)

0 pts

The diagram below shows parts of a torch.

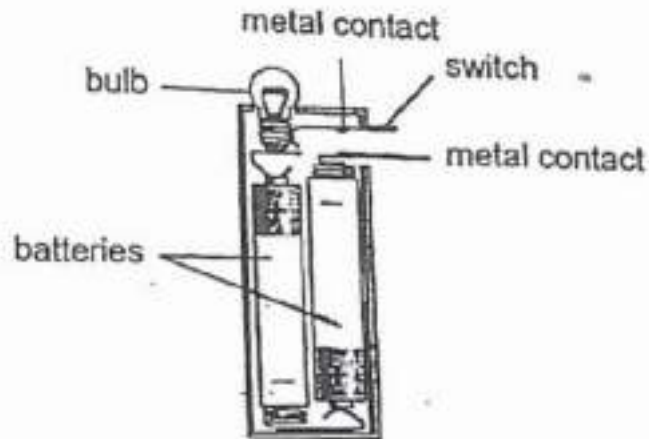

When Ethan bought the torch, a small plastic strip was placed between the metal contacts of the switch as shown in the diagram below.

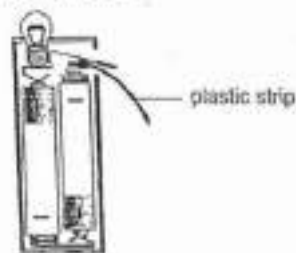

Explain why Ethan had to remove the plastic strip before he could switch on the torch.

[1]

This question is designed for extended answers that parent/ teacher will have to assign and guide child to attempt after the test has been completed.

Grading: This question type is not graded on this system and will not affect the final score as it was designed in such a way that it requires manual assistance.

Question Type: Essay
Date Added: Sat 2nd Oct 2021
Last Modified: N/A
QID#: 29,206,991

Correctly answered feedback

As the plastic strip is an insulator of electricity, electricity cannot flow through the circuit as there is an open circuit. Thus he had to remove it before he could switch on the torch.

Incorrectly answered feedback

As the plastic strip is an insulator of electricity, electricity cannot flow through the circuit as there is an open circuit. Thus he had to remove it before he could switch on the torch.

[Answers](#) | [Edit](#) | [Duplicate](#) | [Used In](#) | [Reorder](#)

[Remove From Test](#)